

Workshop Manual Audi A8 2003 ➤

Direct petrol injection and ignition system (6-cyl. 2.8 ltr.
4-valve)

Engine ID	BDX	CJBA							
-----------	-----	------	--	--	--	--	--	--	--

Edition 09.2010



Audi

Protected by copyright. Copying for private or commercial purposes, in part or in whole, is not permitted unless authorised by AUDI AG. AUDI AG does not guarantee or accept any liability with respect to the correctness of information in this document. Copyright by AUDI AG.

List of Workshop Manual Repair Groups

Repair Group

24 - Mixture preparation - injection

28 - Ignition system



Protected by copyright. Copying for private or commercial purposes, in part or in whole, is not permitted unless authorised by AUDI AG. AUDI AG does not guarantee or accept any liability with respect to the correctness of information in this document. Copyright by AUDI AG.

Technical information should always be available to the foremen and mechanics, because their careful and constant adherence to the instructions is essential to ensure vehicle road-worthiness and safety. In addition, the normal basic safety precautions for working on motor vehicles must, as a matter of course, be observed.

All rights reserved.
No reproduction without prior agreement from publisher.

Contents

24	Mixture preparation - injection	1
1	Safety precautions and rules for cleanliness	1
1.1	Safety precautions	1
1.2	Rules for cleanliness when working on the injection system	2
1.3	Procedure before opening high-pressure section of injection system	2
1.4	Checking vacuum system	3
2	Injection system (Simos)	5
2.1	Technical data	5
2.2	Overview of fitting locations	5
2.3	Air cleaner - exploded view	14
2.4	Removing and installing air filter element	15
2.5	Intake manifold (top section) - exploded view	17
2.6	Removing and installing intake manifold (top section)	19
2.7	Intake manifold (bottom section) with fuel rail - exploded view	21
2.8	Removing and installing intake manifold (bottom section) with fuel rail	22
2.9	Removing and installing injectors	24
2.10	Checking fuel pressure and residual pressure (up to high-pressure fuel pump)	28
2.11	High-pressure fuel pump - exploded view	34
2.12	Removing and installing high-pressure pump	35
2.13	Bleeding fuel system	38
2.14	Lambda probes - overview	38
2.15	Removing and installing Lambda probe G39 before catalytic converter - bank 1 (right-side)	39
2.16	Removing and installing Lambda probe after catalytic converter G130 - bank 1 (right-side)	41
2.17	Removing and installing Lambda probe 2 G108 before catalytic converter - bank 2 (left-side)	43
2.18	Removing and installing Lambda probe 2 after catalytic converter G131 - bank 2 (left-side)	45
3	Engine control unit	48
3.1	Wiring and component check with test box V.A.G 1598/42	48
3.2	Removing and installing engine control unit	50
28	Ignition system	53
1	General notes and safety precautions	53
1.1	Safety precautions	53
2	Servicing ignition system	54
2.1	Test data	54
2.2	Ignition system - exploded view	54
2.3	Removing and installing ignition coils	55
2.4	Removing and installing knock sensors	56

Protected by copyright. Copying for private or commercial purposes, in part or in whole, is not permitted unless authorised by AUDI AG. AUDI AG does not guarantee or accept any liability with respect to the correctness of information in this document. Copyright by AUDI AG.



Audi

Protected by copyright. Copying for private or commercial purposes, in part or in whole, is not permitted unless authorised by AUDI AG. AUDI AG does not guarantee or accept any liability with respect to the correctness of information in this document. Copyright by AUDI AG.

24 – Mixture preparation - injection

1 Safety precautions and rules for cleanliness

1.1 Safety precautions

Note the following if testers and measuring instruments have to be used during a road test:



WARNING

Accidents can be caused if the driver is distracted by test equipment while road-testing, or if test equipment is not properly secured.

Persons sitting in the front passenger's seat could be injured if the airbag is triggered in an accident.

- *The use of test equipment while driving causes distraction.*
- *There is an increased risk of injury if test equipment is not secured.*
- ◆ *Test equipment must always be secured on the rear seat with a strap and operated from the rear seat by a second person.*

To prevent injuries to persons and/or irreparable damage to the fuel injection and ignition system, the following must be noted:



WARNING

Protected by copyright. Copying for private or commercial purposes, in part or in whole, is not permitted unless authorised by AUDI AG. AUDI AG does not guarantee or accept any liability with respect to the correctness of information in this document. Copyright by AUDI AG.

- ◆ *The fuel system operates under high pressure. The pressure in the high-pressure part of the injection system must be reduced to a residual pressure prior to opening the system ⇒ [page 2](#).*
- ◆ *A clean cloth must then be wrapped around the connection and the residual pressure dissipated by carefully loosening the connection.*



Caution

- ◆ *Observe notes on procedure for disconnecting the battery ⇒ [Electrical system](#); [Rep. gr. 27](#); [Battery](#); [Disconnecting and connecting battery](#).*



- ◆ If the battery is NOT disconnected, fuse in -relay and fuse holder in luggage compartment (right-side)- for the fuel pump control unit -J538- must be removed as a precautionary measure before opening the fuel system, because the fuel pump will otherwise be activated by the contact switch on the driver's door.
- ◆ Persons wearing a cardiac pacemaker must at all times maintain a safe distance from high-voltage components such as the ignition system and gas-discharge headlights.
- ◆ Do not open any fuel line connections while the engine is running.
- ◆ Always switch off the ignition before connecting or disconnecting injection or ignition system wiring or tester cables.
- ◆ If the engine is to be operated at cranking speed without it starting (e.g. compression test), unplug the connectors from the ignition coils and remove the fuse for the electric fuel pump.
- ◆ Certain tests may lead to a fault being detected by the control unit and stored. The event memory should therefore be interrogated and (if necessary) erased after completing the tests and any repair work that may be required.
- ◆ Always switch off the ignition before cleaning the engine.

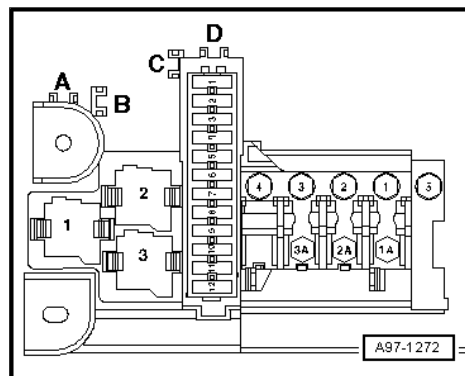

1.2 Rules for cleanliness when working on the injection system

Even small amounts of dirt can cause faults in the injection system. When working on the fuel supply/injection system, pay careful attention to the following basic rules:

- ◆ Carefully clean connection points and the surrounding area with engine cleaner or brake cleaner and **dry thoroughly before opening**.
- ◆ Plug open lines and connections with suitable protective caps immediately.
- ◆ Place parts that have been removed on a clean surface and cover them over. Do not use fluffy cloths.
- ◆ Only install clean components; replacement parts should only be unpacked immediately prior to installation. Do not use parts that have been previously unpacked and stored away loose (e.g. in toolboxes, etc.).
- ◆ When the system is open: Do not work with compressed air. Do not move the vehicle unless absolutely necessary.

1.3 Procedure before opening high-pressure section of injection system



Caution

The injection system consists of a high-pressure section (maximum approx. 120 bar) and a low-pressure section (approx. 7 bar).

Prior to opening the high-pressure section (e.g. when removing the high-pressure pump, fuel rail, injectors, fuel pipes or fuel pressure sender -G247-), the fuel pressure in the high-pressure section must be reduced to a residual pressure of approx. 7 bar. The procedure is described below.

Reducing fuel pressure in high-pressure section

- Connect a vehicle diagnostic tester.
- Start engine and run at idling speed.
- Select „Engine electronics“ in vehicle self-diagnosis.
- Then select „Basic setting“.
- Select measured value block 140 in basic setting function.
- With engine idling the fuel pressure is displayed in zone 3.
- ◆ Specification: between 35 and 45 bar
- Activate basic setting by touching key.
- The fuel pressure should drop now.

Example:

- 1 - 0 %
- 2 - 0 bar
- 3 - 5.46 bar
- 4 - reduce
- Switch off ignition as soon as fuel pressure has dropped to approx. 6 bar.

The fuel rail is still filled with fuel, however it is no longer under high pressure.

 **WARNING**

There is a risk of injury: avoid skin contact with fuel.

- ◆ *Wear safety goggles and protective clothing when opening the fuel system.*
- ◆ *Before opening the high-pressure section of the fuel system, place a clean cloth around the connection to catch escaping fuel.*

Protective copyright. Copying for private or commercial purposes is allowed only if permitted in writing by AUDI AG. AUDI AG does not guarantee or accept any liability with respect to the correctness of information in this document. Copyright by AUDI AG.

The high-pressure system must be opened »immediately« after reducing the fuel pressure; wrap a clean cloth around the connection. Catch the escaping fuel.

Additional steps required

- Erase event memory and generate readiness code in engine control unit in „Guided Functions“ mode.

1.4 Checking vacuum system

Special tools and workshop equipment required



◆ Hand vacuum pump -VAS 6213-

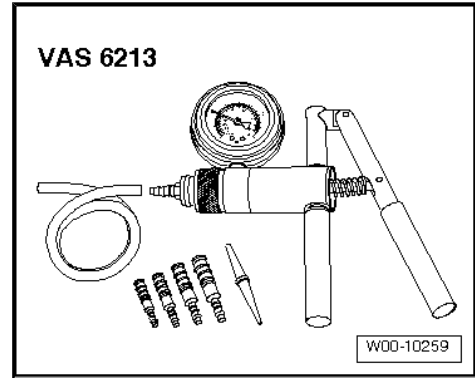

Procedure

- Check all vacuum lines in the complete vacuum system for:
 - ◆ Cracks
 - ◆ Traces of animal bites
 - ◆ Kinked or crushed lines
 - ◆ Lines porous or leaking
- Check vacuum line to solenoid valve and from solenoid valve to corresponding component.
- If a fault is stored in the event memory, check the vacuum lines leading to the corresponding component and also check the remaining vacuum lines leading to other components.
- If it is not possible to build up pressure with the hand vacuum pump -VAS 6213- or if the pressure drops again immediately, check the hand vacuum pump and connecting hoses for leaks.



Audi

Protected by copyright. Copying for private or commercial purposes, in part or in whole, is not permitted unless authorised by AUDI AG. AUDI AG does not guarantee or accept any liability with respect to the correctness of information in this document. Copyright by AUDI AG.

2 Injection system (Simos)

2.1 Technical data

Test data	2.8 ltr. / 4V / 154 kW engine
Idling speed Cannot be adjusted; regulated by idling speed stabilisation	650 ... 750 rpm ¹⁾
Fuel pressure after high-pressure fuel pump	40 ... 110 bar
Fuel pressure before high-pressure fuel pump	3.0 ... 5.7 bar
<ul style="list-style-type: none"> • ¹⁾ Depending on demands placed on engine control unit. 	

2.2 Overview of fitting locations

Engine compartment (right-side)

1 - Ignition coils for cylinder bank 1

- Ignition coil 1 with output stage -N70-
- Ignition coil 2 with output stage -N127-
- Ignition coil 3 with output stage -N291-
- Removing and installing
⇒ [page 55](#)

2 - Right electrohydraulic engine mounting solenoid valve N145-

- Fitting location
⇒ [page 13](#)

3 - Hall sender 3 -G300-

- Fitting location
⇒ [page 11](#)

4 - Lambda probe -G39-

- Fitting location
⇒ [page 10](#)
- Fitting location of connector ⇒ [page 9](#)
- Removing and installing
⇒ [page 39](#)
- Tightening torque: 55 Nm

5 - Engine control unit -J623-

- Fitting location
⇒ [page 8](#)
- Removing and installing
⇒ [page 50](#)
- After renewing, adapt throttle valve module in mode „Guided Fault Finding“, option „Adapt throttle valve module“
- After renewing, also perform kick-down adaption in „Guided Fault Finding“, option „Adapt kickdown point“

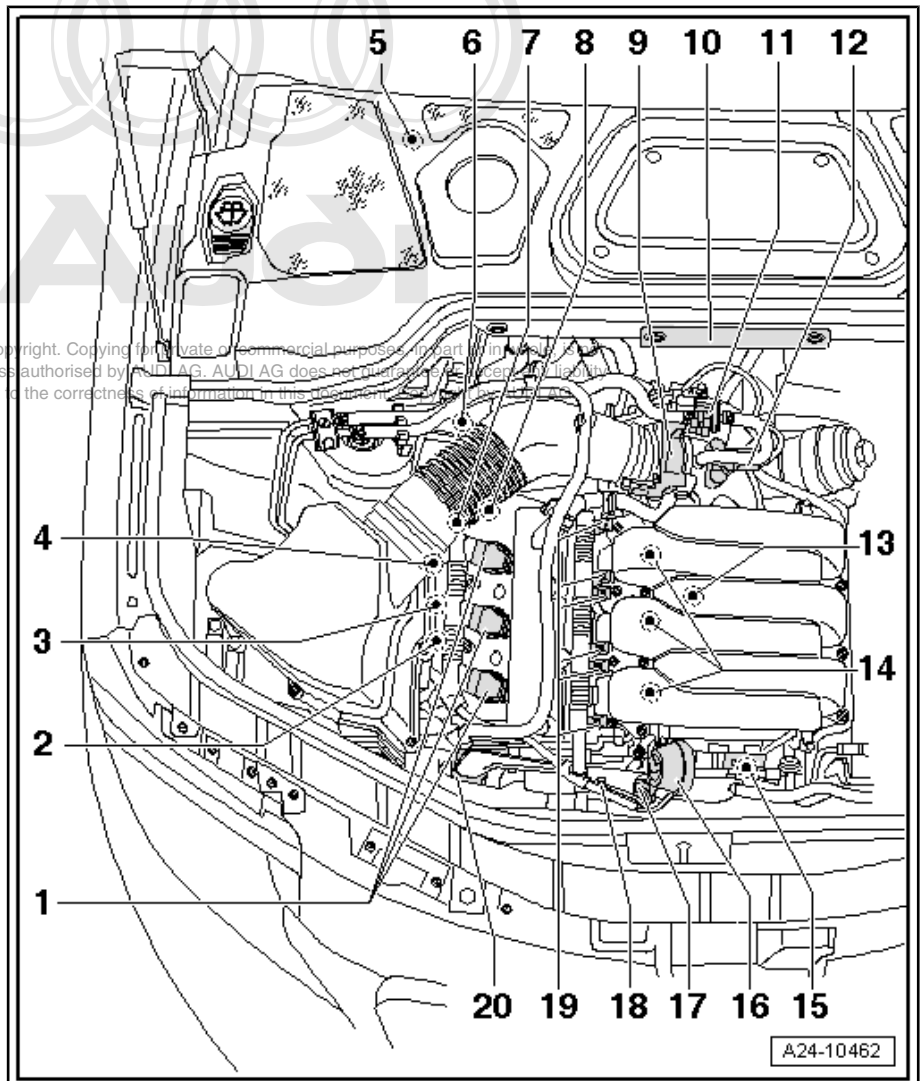



6 - Lambda probe after catalytic converter -G130-

- Fitting location ⇒ [page 10](#)
- Fitting location of connector ⇒ [page 9](#)
- Removing and installing ⇒ [page 41](#)
- Tightening torque: 55 Nm

7 - Exhaust camshaft control valve 1 -N318-

- Fitting location ⇒ [page 11](#)

8 - Camshaft control valve 1 -N205-

- Fitting location ⇒ [page 11](#)

9 - Throttle valve module -J338-

- Including throttle valve drive for electric throttle -G186-, throttle valve drive angle sender 1 for electric throttle -G187- and throttle valve drive angle sender 2 for electric throttle -G188-
- After renewing adapt in mode „Guided Fault Finding“, option „Adapt throttle valve module“.
- Fitting location ⇒ [page 12](#)

10 - Bracket for connectors

- Fitting locations of connectors ⇒ [page 9](#)

11 - Activated charcoal filter solenoid valve 1 -N80-

12 - Intake air temperature sender -G42- / intake manifold pressure sender -G71-

- Fitting location ⇒ [page 12](#)

13 - Knock sensor 1 -G61-

- Fitting location ⇒ [page 12](#)
- Fitting location of connector ⇒ [page 10](#)
- Removing and installing ⇒ [page 56](#)
- Tightening torque: 20 Nm

14 - Injectors, cylinder bank 1

- Injector, cylinder 1 -N30-
- Injector, cylinder 2 -N31-
- Injector, cylinder 3 -N32-
- Removing and installing ⇒ [page 24](#)

15 - Variable intake manifold change-over valve -N156-

Fitting location ⇒ [page 11](#)

16 - Actuator for intake manifold changeover

Protected by copyright. Copying for private or commercial purposes, in part or in whole, is not allowed unless authorised by AUDI AG. AUDI AG does not guarantee or accept any liability with respect to the correctness of information in this document. Copyright by AUDI AG.

17 - Coolant temperature sender -G62-

- Fitting location ⇒ [page 11](#)

18 - Hall sender -G40-

- Fitting location ⇒ [page 11](#)

19 - Actuators for camshaft adjustment

- Actuator 1 for camshaft adjustment -F366-
- Actuator 2 for camshaft adjustment -F367-
- Actuator 3 for camshaft adjustment -F368-
- Actuator 4 for camshaft adjustment -F369-
- Actuator 5 for camshaft adjustment -F370-
- Actuator 6 for camshaft adjustment -F371-
- Fitting location ⇒ [page 11](#)

20 - High-pressure fuel pump

- With fuel pressure sender, low pressure -G410- and fuel metering valve -N290-

- Fitting location ⇒ [page 12](#)

Engine compartment (left-side)

1 - Fuel pressure sender - G247-

- Fitting location ⇒ [page 12](#)

2 - Knock sensor 2 -G66-

- Fitting location ⇒ [page 12](#)
- Fitting location of connector ⇒ [page 10](#)
- Removing and installing ⇒ [page 56](#)
- Tightening torque: 20 Nm

3 - Injectors, cylinder bank 2

- Injector, cylinder 4 - N33-
- Injector, cylinder 5 - N83-
- Injector, cylinder 6 - N84-
- Removing and installing ⇒ [page 24](#)

4 - Engine speed sender -G28-

- Fitting location ⇒ [page 13](#)

5 - Instrument cluster

- With exhaust emissions warning lamp -K83- („MIL“ lamp) and electronic power control fault lamp -K132- („EPC“ lamp)

6 - Accelerator position sender -G79- and accelerator position sender 2 -G185-

- In accelerator pedal module; fitting location ⇒ [page 9](#)

7 - Brake light switch -F- / brake pedal switch -F47-

- Fitting location ⇒ [page 9](#)

8 - Lambda probe 2 after catalytic converter -G131-

- Fitting location ⇒ [page 10](#)
- Fitting location of connector ⇒ [page 9](#)
- Removing and installing ⇒ [page 45](#)
- Tightening torque: 55 Nm

9 - Camshaft control valve 2 -N208-

Fitting location ⇒ [page 11](#)

10 - Exhaust camshaft control valve 2 -N319-

- Fitting location ⇒ [page 11](#)

11 - Lambda probe 2 -G108-

- Fitting location ⇒ [page 10](#)

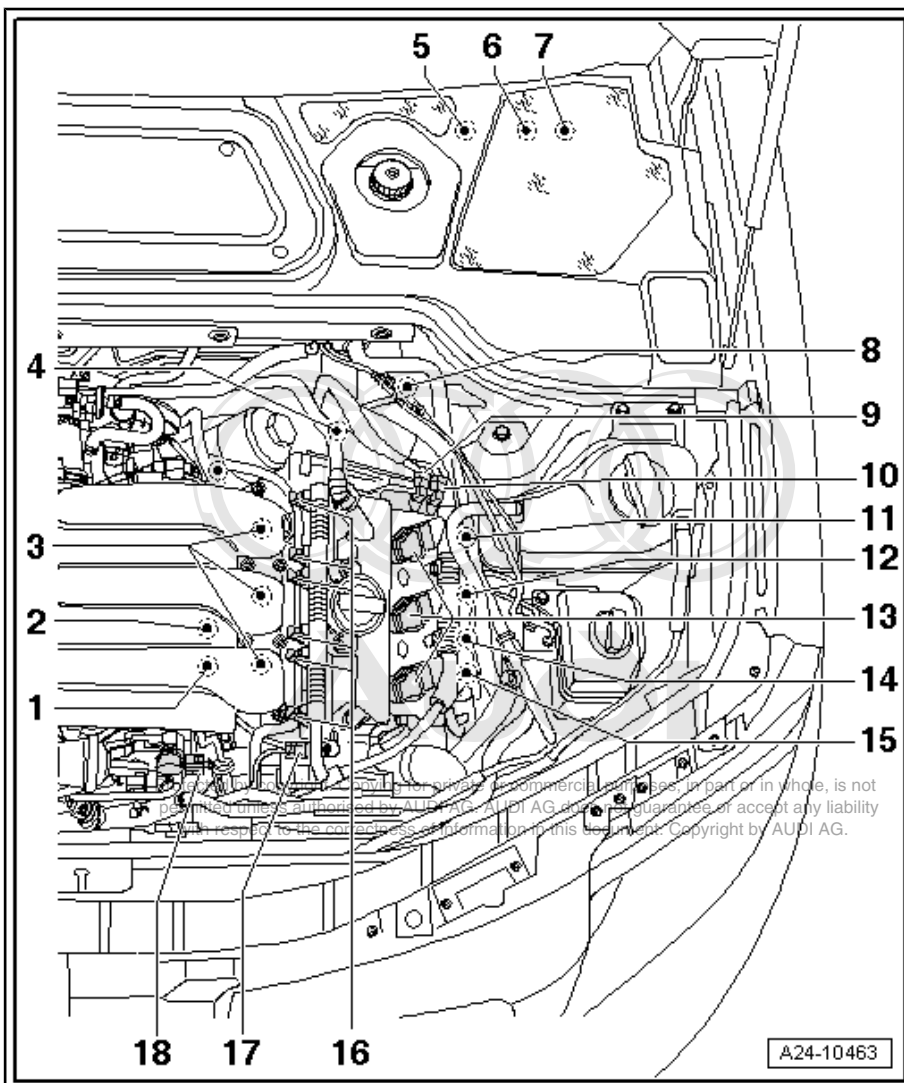



- Fitting location of connector ⇒ [page 9](#)
- Removing and installing ⇒ [page 43](#)
- Tightening torque: 55 Nm

12 - Hall sender 4 -G301-

- Fitting location ⇒ [page 11](#)

13 - Ignition coils for cylinder bank 2

- Ignition coil 4 with output stage -N292-
- Ignition coil 5 with output stage -N323-
- Ignition coil 6 with output stage -N324-
- Removing and installing ⇒ [page 55](#)

14 - Left electrohydraulic engine mounting solenoid valve -N144-

- Fitting location ⇒ [page 13](#)

15 - Valve for oil pressure control -N428-

- Removing and installing ⇒ Rep. gr. 17

16 - Actuators for camshaft adjustment

- Actuator 7 for camshaft adjustment -F372-
- Actuator 8 for camshaft adjustment -F373-
- Actuator 9 for camshaft adjustment -F374-
- Actuator 10 for camshaft adjustment -F375-
- Actuator 11 for camshaft adjustment -F376-
- Actuator 12 for camshaft adjustment -F377-
- Fitting location ⇒ [page 11](#)

17 - Hall sender 2 -G163-

- Fitting location ⇒ [page 11](#)

18 - Variable intake manifold position sender -G513-

- Fitting location ⇒ [page 11](#)

Fitting location of engine control unit -J623-

- ◆ The engine control unit -J623- -Item 1- is located on top of electronics box at plenum chamber.

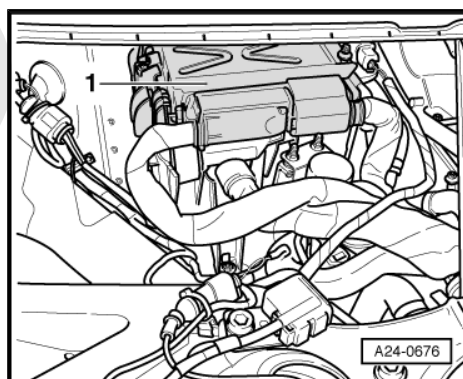

Protected by copyright. Copying for private or commercial purposes, in part or in whole, is not permitted unless authorised by AUDI AG. AUDI AG does not guarantee or accept any liability with respect to the correctness of information in this document. Copyright by AUDI AG.

Fitting location of accelerator position sender -G79- / accelerator position sender 2 -G185-

◆ In accelerator pedal module -arrow-

 **Note**

The accelerator position sender -G79- and accelerator position sender 2 -G185- are integrated in the accelerator pedal module and cannot be renewed individually.

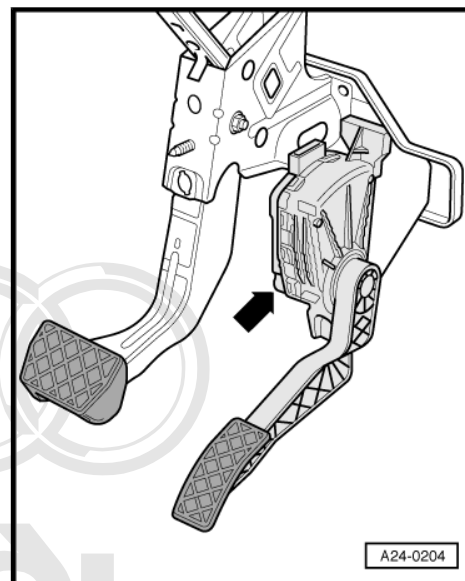

Fitting location of brake light switch -F- and brake pedal switch -F47-

◆ On pedal bracket -arrow-

 **Note**

Switches must not be installed more than once, otherwise they may not fit securely.

Protected by copyright. Copying for private or commercial purposes is not permitted unless authorised by AUDI AG. AUDI AG does not guarantee or accept any liability with respect to the correctness of information in this document. Copyright © AUDI AG

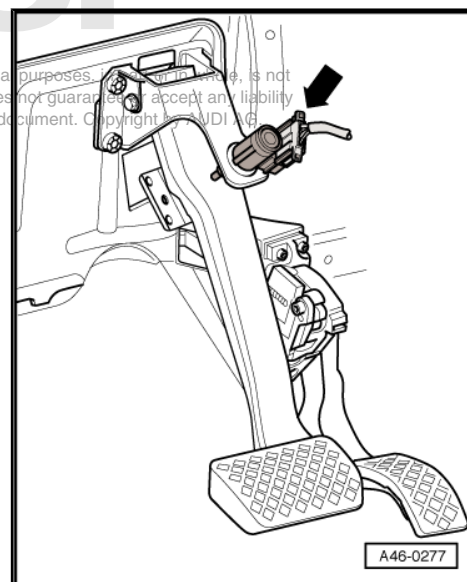

Bracket for connectors on plenum chamber partition panel

- 1 - To Lambda probe after catalytic converter -G130-
- 2 - To Lambda probe -G39-
- 3 - To Lambda probe 2 -G108-
- 4 - To Lambda probe 2 after catalytic converter -G131-

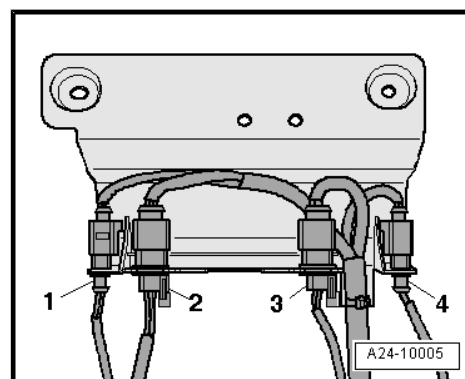



Fitting location of Lambda probes on cylinder bank 1 (right-side)

- 1 - Lambda probe after catalytic converter -G130-
- 2 - Lambda probe -G39-

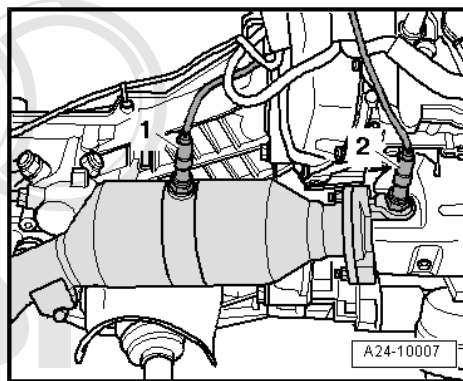

Fitting location of Lambda probes on cylinder bank 2 (left-side)

- 1 - Lambda probe 2 -G108-
- 2 - Lambda probe 2 after catalytic converter -G131-

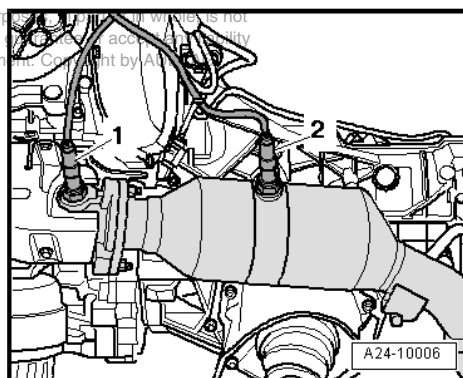

Electrical connectors at rear right of engine

- 1 - To injectors on cylinder bank 1



Note

The -arrow- indicates the earth point.

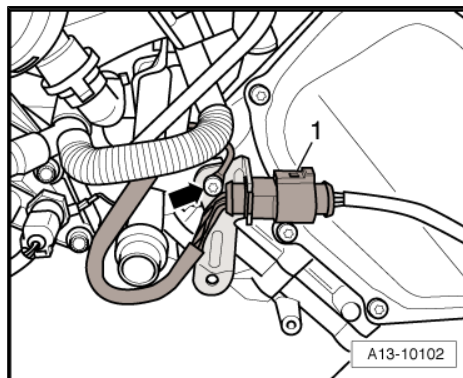

Electrical connectors at rear left of engine

- 1 - Green; to knock sensor 1 -G61-
- 2 - Grey; to knock sensor 2 -G66-
- 3 - To injectors on cylinder bank 2 and to fuel pressure sender -G247-



Note

The -arrow- indicates the earth point.

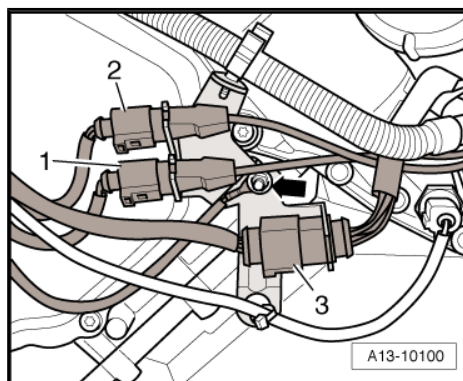

Hall senders, actuators and valves for camshaft adjustment on cylinder bank 1 (right-side)

- 1 - Hall sender 3 -G300-
- 2 - Exhaust camshaft control valve 1 -N318-
- 3 - Camshaft control valve 1 -N205-
- 4 - Actuator 6 for camshaft adjustment -F371-
- 5 - Actuator 5 for camshaft adjustment -F370-
- 6 - Actuator 4 for camshaft adjustment -F369-
- 7 - Actuator 3 for camshaft adjustment -F368-
- 8 - Actuator 2 for camshaft adjustment -F367-
- 9 - Actuator 1 for camshaft adjustment -F366-
- 10 - Hall sender -G40-

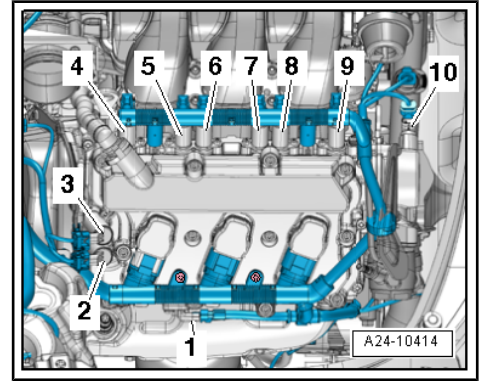

Hall senders, actuators and valves for camshaft adjustment on cylinder bank 2 (left-side)

- 1 - Hall sender 2 -G163-
- 2 - Actuator 7 for camshaft adjustment -F372-
- 3 - Actuator 8 for camshaft adjustment -F373-
- 4 - Actuator 9 for camshaft adjustment -F374-
- 5 - Actuator 10 for camshaft adjustment -F375-
- 6 - Actuator 11 for camshaft adjustment -F376-
- 7 - Actuator 12 for camshaft adjustment -F377-
- 8 - Camshaft control valve 2 -N208-
- 9 - Exhaust camshaft control valve 2 -N319-
- 10 - Hall sender 4 -G301-

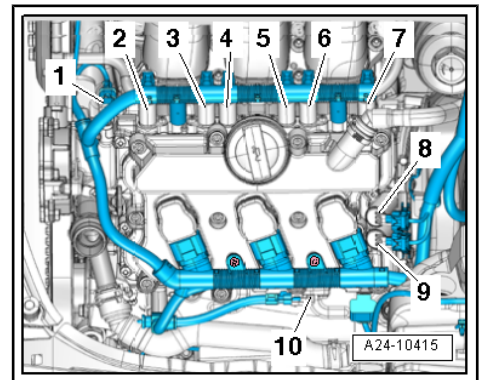

Fitting location: at front of engine

- 1 - Coolant temperature sender -G62-
- 2 - Variable intake manifold change-over valve -N156-
- 3 - Variable intake manifold position sender -G513-

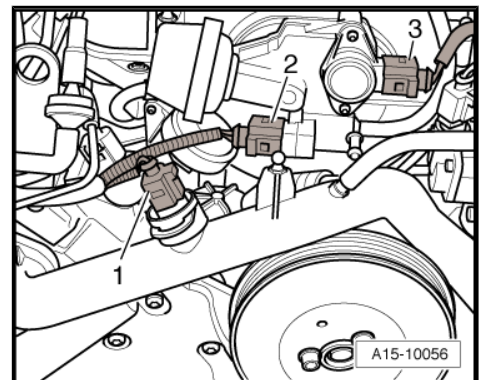

Protected by copyright. Copying for private or commercial purposes, in part or in whole, is not permitted unless authorised by AUDI AG. AUDI AG does not guarantee or accept any liability with respect to the correctness of information in this document. Copyright by AUDI AG.



Fitting location: at rear of intake manifold

- 1 - Throttle valve module -J338-
- 4 - Intake air temperature sender -G42- / intake manifold pressure sender -G71-



Note

Disregard -items 2, 3- and -arrow-.

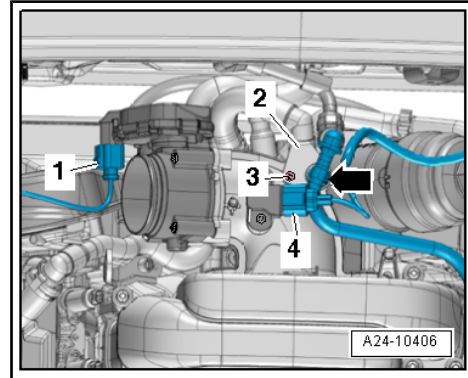

Fitting locations at high-pressure fuel pump

- 1 - Fuel pressure sender for low pressure -G410-
- 2 - Fuel metering valve -N290-

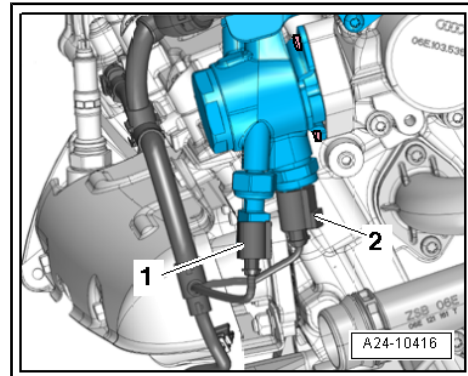

Fitting locations below intake manifold on cylinder bank 1 (right-side)

- 1 - Injector, cylinder 1 -N30-
- 2 - Injector, cylinder 2 -N31-
- 3 - Injector, cylinder 3 -N32-
- 4 - Knock sensor 1 -G61-

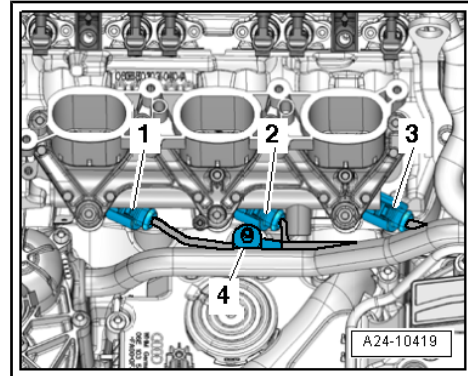

Fitting locations below intake manifold on cylinder bank 2 (left-side)

- 1 - Injector, cylinder 6 -N84-
- 2 - Injector, cylinder 5 -N83-
- 3 - Injector, cylinder 4 -N33-
- 4 - Fuel pressure sender -G247-
- 5 - Knock sensor 2 -G66-

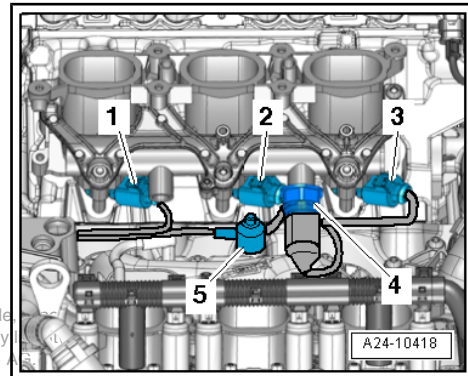

Protected by copyright. Copying for private or commercial purposes, in part or in whole, is permitted unless authorised by AUDI AG. AUDI AG does not guarantee or accept any liability with respect to the correctness of information in this document. Copyright by AUDI AG.

Fitting location of engine speed sender -G28-

- ◆ At front left of gearbox housing -arrow-

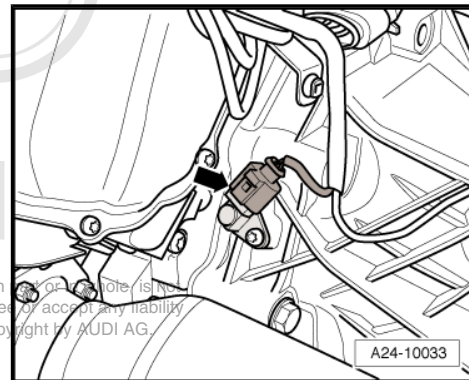
**Fitting location of solenoid valves for electro-hydraulic engine mountings and valves for gearbox mountings**

- ◆ Left electro-hydraulic engine mounting solenoid valve -N144-
- ◆ Right electrohydraulic engine mounting solenoid valve -N145-
- ◆ Gearbox mounting valve 1 -N262-
- ◆ Gearbox mounting valve 2 -N263-

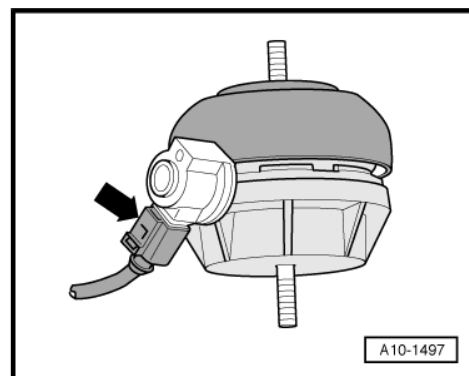



2.3 Air cleaner - exploded view

1 - Water drain hose

- Check for dirt and clean as required (inspect valve)
- Water drain must function properly

2 - Air cleaner (bottom section)

- Clean out salt deposits, dirt and leaves, etc.
- Check for dirt in water drain (inspect valve)

3 - Bolt

4 - Air filter element

- Always use genuine part for air filter element
- Removing and installing ⇒ [page 15](#)
- Intervals for changing filter ⇒ Maintenance ; Booklet 404

5 - Air duct

- Clean out dirt and leaves, etc.

6 - Air cleaner (top section)

- Clean out salt deposits, dirt and leaves, etc.

7 - O-ring

- Renew

8 -

9 - Spring-type clip

10 - Air hose

11 - Bolt

12 - Bolt

13 - Not fitted

14 - Not fitted

15 - Bolt

- 5 Nm

16 - Spacer sleeve

17 - Rubber grommet

18 - Rubber mounting

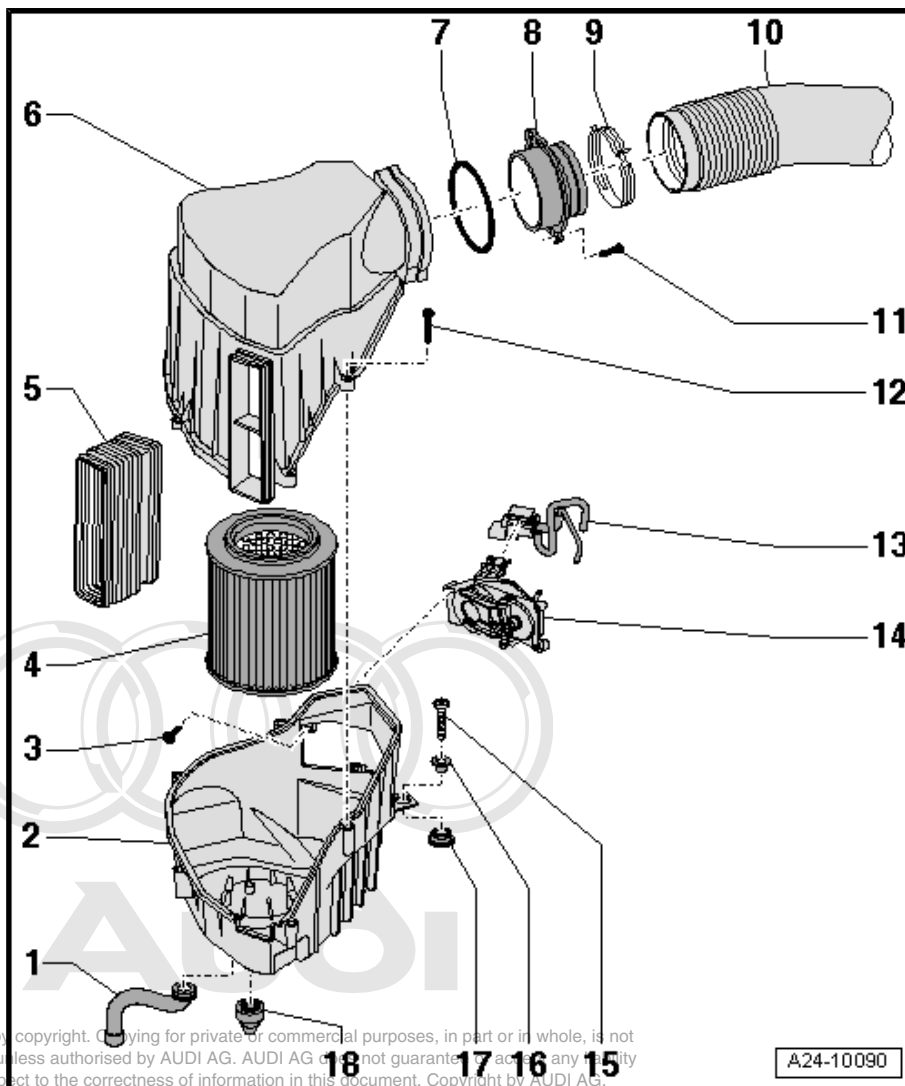

Protected by copyright. Copying for private or commercial purposes, in part or in whole, is not permitted unless authorised by AUDI AG. AUDI AG does not guarantee accuracy in any language with respect to the correctness of information in this document. Copyright by AUDI AG.

A24-10090

2.4 Removing and installing air filter element

Removing

- Disconnect non-return valve -2- from connection on air hose.
- Unclip vacuum line -1- and fuel line -3- from retainer on air hose.
- Release hose clips -arrows- and remove air hose.

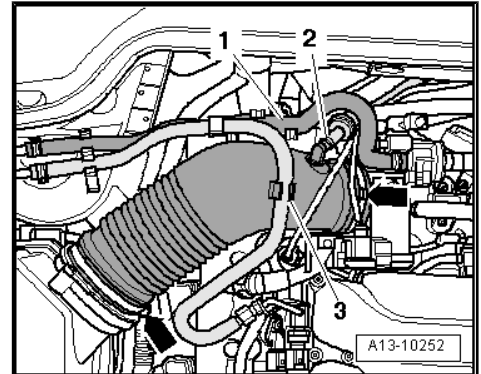

Protected by copyright. Copying for private or commercial purposes, in part or in whole, is not permitted unless authorised by AUDI AG. AUDI AG does not guarantee or accept any liability with respect to the correctness of information in this document. Copyright by AUDI AG.



- Unscrew bolts -arrows- and remove air cleaner housing (top section).
- Take out air filter element.

Installing



Note

- ◆ Always use genuine part for air filter element.
- ◆ Hose connections and hoses in intake system must be free of oil and grease before assembly. Do not use any lubricants containing silicone when assembling.
- ◆ The air cleaner housing **MUST** be clean.
- ◆ Secure all hose connections with the correct type of hose clips (same as original equipment) ⇒ *Electronic parts catalogue*.
- ◆ To prevent malfunctions, cover all critical parts of the engine air intake tract (intake pipes, etc.) with a clean cloth when blowing out the air cleaner housing with compressed air.
- ◆ Please observe requirements for disposal.

- Tightening torques: refer to air cleaner - exploded view ⇒ [page 14](#) .

- Blow out water drain (small hole in bottom section of air cleaner housing) with compressed air.
- Clean salt residue, dirt and leaves out of air cleaner housing (top and bottom sections); use vacuum cleaner if necessary.
- Check for salt residue, dirt and leaves in air hose (engine intake side).
- Check for dirt and leaves in air duct going from lock carrier to air cleaner housing.
- When installing the air filter element, check that it is properly centred in the retainer in the bottom section of the air cleaner housing.
- Carefully fit top section of air cleaner onto bottom section, without using any force. Make sure the top section of the air cleaner housing is fitted straight on the air filter element (note sealing lip on air filter element).

The remaining installation steps are carried out in the reverse sequence.

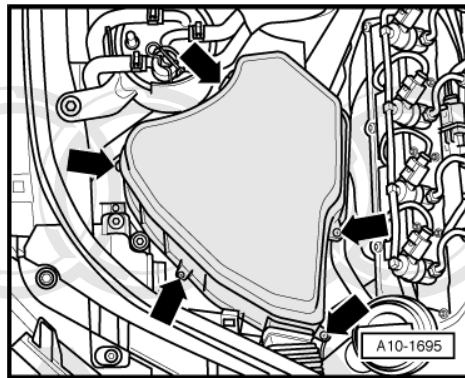

Copyrighted by copyright. Copying for private or commercial purposes, in part or in whole, is not permitted unless authorised by AUDI AG. AUDI AG does not guarantee or accept any liability in respect to the correctness of information in this document. Copyright by AUDI AG.

2.5 Intake manifold (top section) - exploded view

1 - Vacuum hose

2 - Variable intake manifold change-over valve -N156-

3 - Bolt

- 2.5 Nm

4 - Bolt

- 2.5 Nm

5 - Actuator for intake manifold change-over

- Installation position of toothed segments for intake manifold change-over => [page 18](#)
- Replacement part is supplied together with -item 26-

6 - Seal

- Renew if damaged
- When renewing lever out with screwdriver
- Press in by hand

7 - Ball stud

- 2.5 Nm

8 - Intake manifold (top section)

- Removing and installing => [page 19](#)

9 - Seal

- Renew

10 - Throttle valve module - J338-

11 - Bracket

12 - Bolt

- 6 Nm

13 - Activated charcoal filter solenoid valve 1 -N80-

14 - Hose

15 - Bolt

- 3 Nm

16 - Intake air temperature sender -G42- / intake manifold pressure sender -G71-

17 - O-ring

- Renew

18 - Bolt

- 2.5 Nm

19 - Crankcase breather hose

20 - O-ring

- Renew

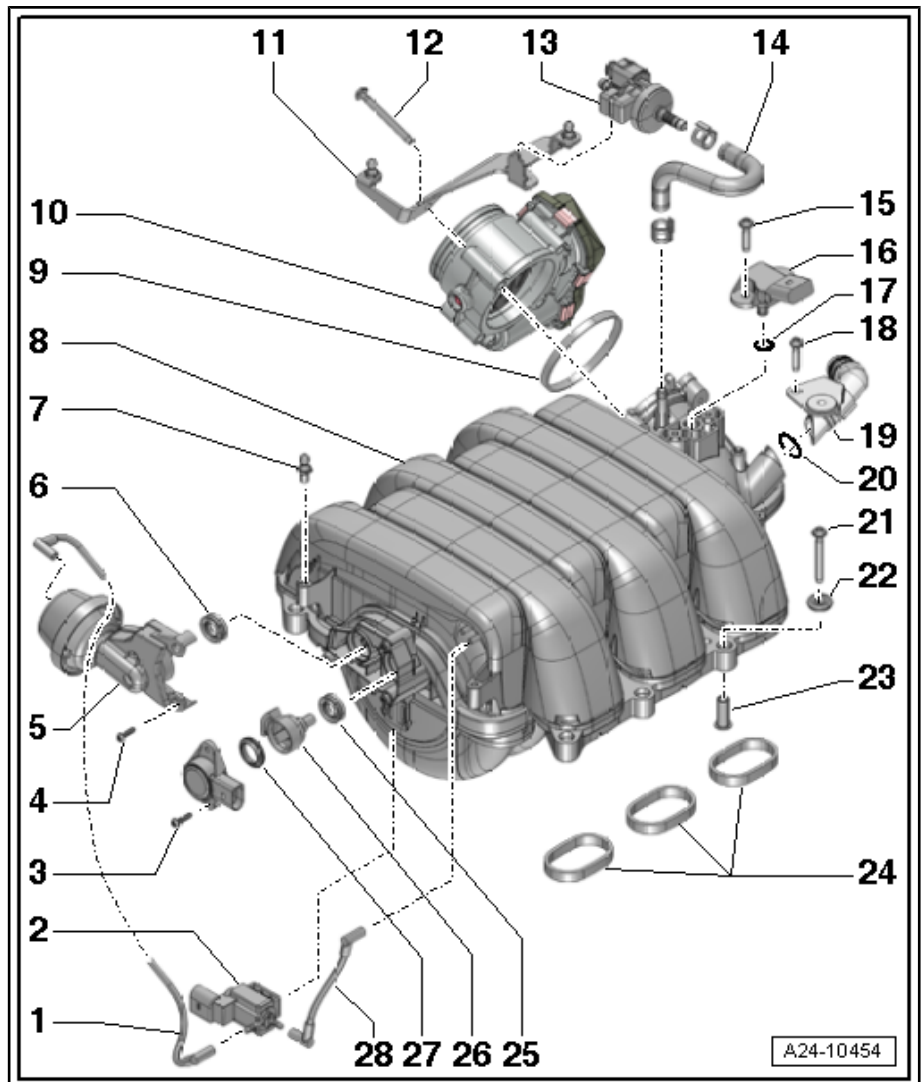

Protected by copyright. Copying for private or commercial purposes, in part or in whole, is not permitted unless authorised by AUDI AG. AUDI AG does not guarantee or accept any liability with respect to the correctness of information in this document. Copyright by AUDI AG.

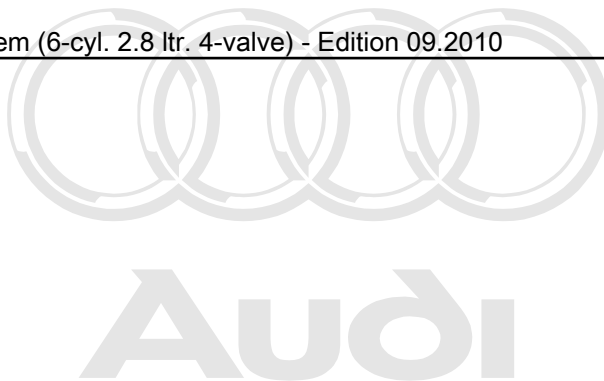

21 - Bolt

- 8 Nm

22 - Washer

23 - Sleeve

24 - Seals

- Renew

25 - Seal

- Renew if damaged
- When renewing lever out with screwdriver
- Press in by hand

Protected by copyright. Copying for private or commercial purposes, in part or in whole, is not permitted unless authorised by AUDI AG. AUDI AG does not guarantee or accept any liability with respect to the correctness of information in this document. Copyright by AUDI AG.

26 - Lever with toothed segment

- For intake manifold change-over
- Installation position of toothed segments ⇒ [page 18](#)
- Replacement part is supplied together with -item 5-

27 - Seal

- Renew if damaged
- When renewing lever out with screwdriver
- Press in by hand

28 - Vacuum hose

Installation position of toothed segments for intake manifold change-over

- The lower edges of the toothed segments must be flush -arrows-.

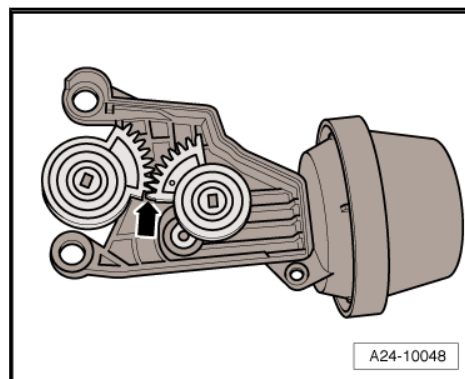

2.6 Removing and installing intake manifold (top section)

Removing

- Pull off engine cover panels -arrows-.

 **Note**

Fit all cable ties in the original positions when installing.

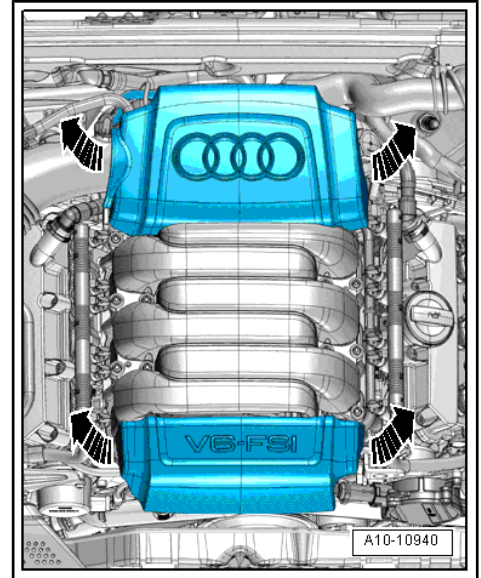

- Disconnect non-return valve -2- from connection on air hose.
- Unclip vacuum line -1- and fuel line -3- from retainer on air hose.
- Release hose clips -arrows- and remove air hose.

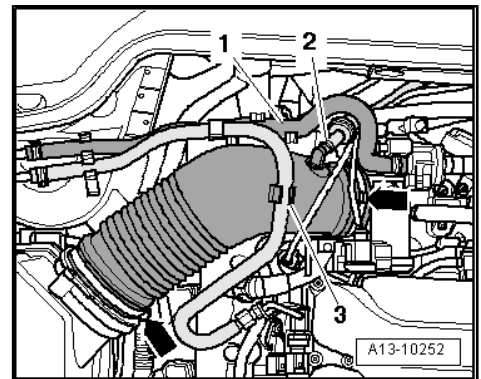

- Unplug electrical connector -1- at activated charcoal filter solenoid valve 1 -N80- and detach vacuum hose -2-.
- Detach activated charcoal filter solenoid valve 1 -N80- from bracket and move it clear to the side with hose still attached.

 **Note**

Ignore arrow. Protected by copyright. Copying for private or commercial purposes, in part or in whole, is not permitted unless authorised by AUDI AG. AUDI AG does not guarantee or accept any liability with respect to the correctness of information in this document. Copyright by AUDI AG.

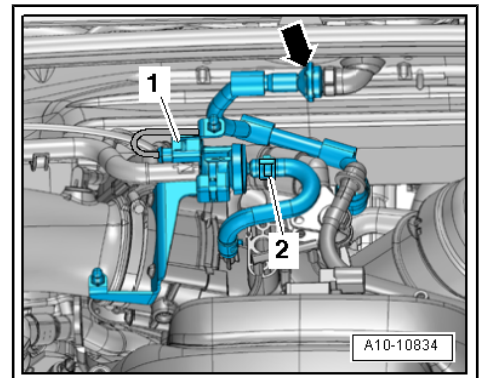



- Unplug electrical connectors:
- 1 - Variable intake manifold change-over valve -N156-
- 2 - Variable intake manifold position sender -G513-
- Detach vacuum hose -arrow-.

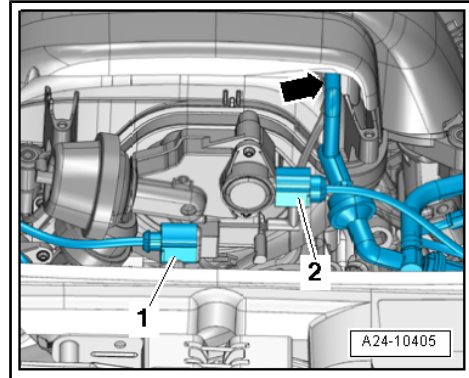

- Unplug electrical connectors:
- 1 - Throttle valve module -J338-
- 4 - Intake air temperature sender -G42- / intake manifold pressure sender -G71-
- Move clear vacuum hose -arrow-.
- Move clear electrical wiring harness.
- Remove bolt -3-.
- Press retaining tab -2- up slightly and detach crankcase breather hose from intake manifold.

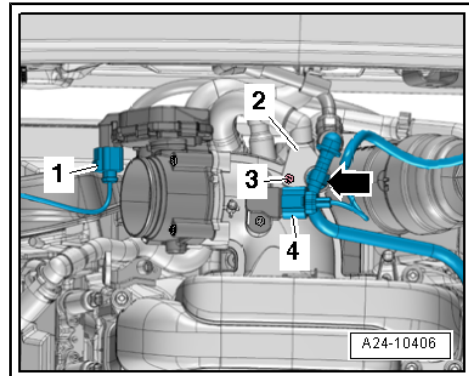

- Remove bolts -arrows- and detach intake manifold (top section).

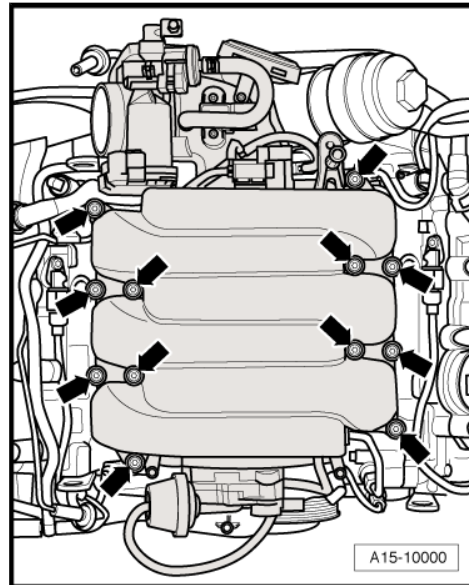

Caution

Risk of irreparable damage to engine.

- ◆ *Block off the intake manifolds (bottom section) with clean cloths to prevent small objects from dropping into the engine through the intake ports in the cylinder heads.*

Installing

- Tightening torque = [page 17](#)
- Installation is carried out in the reverse order, note the following:



Note

- ◆ *Renew gaskets and O-rings.*
- ◆ *Fit all cable ties in the original positions when installing.*
- ◆ *Secure all hose connections with the correct type of hose clips (same as original equipment) ⇒ Parts catalogue.*

2.7 Intake manifold (bottom section) with fuel rail - exploded view

1 - Intake manifold (bottom section)

- Removing and installing
 ⇒ [page 22](#)

2 - Sleeve

3 - Fuel pressure sender - G247-

- 20 Nm

4 - Bracket

5 - Bolt

- 9 Nm

6 - High-pressure pipe

⚠ WARNING

The fuel system operates at extremely high pressure. This can cause injury. The fuel pressure in the high-pressure section of the injection system must be reduced to a residual pressure prior to opening the system.

- Reducing fuel pressure in high-pressure section of injection system
 ⇒ [page 2](#)

- Do not alter shape
- Tightening ⇒ [page 22](#)

7 - Bolt

- 9 Nm

8 - Threaded connection

- 40 Nm

9 - Stud

10 - Nut

- 9 Nm

11 - Retainer for fuel rail

12 - Bolt

- 2.5 Nm

13 - Bolt

- 9 Nm

14 - Sleeve

15 - Fuel rail

16 - Seals

- Renew

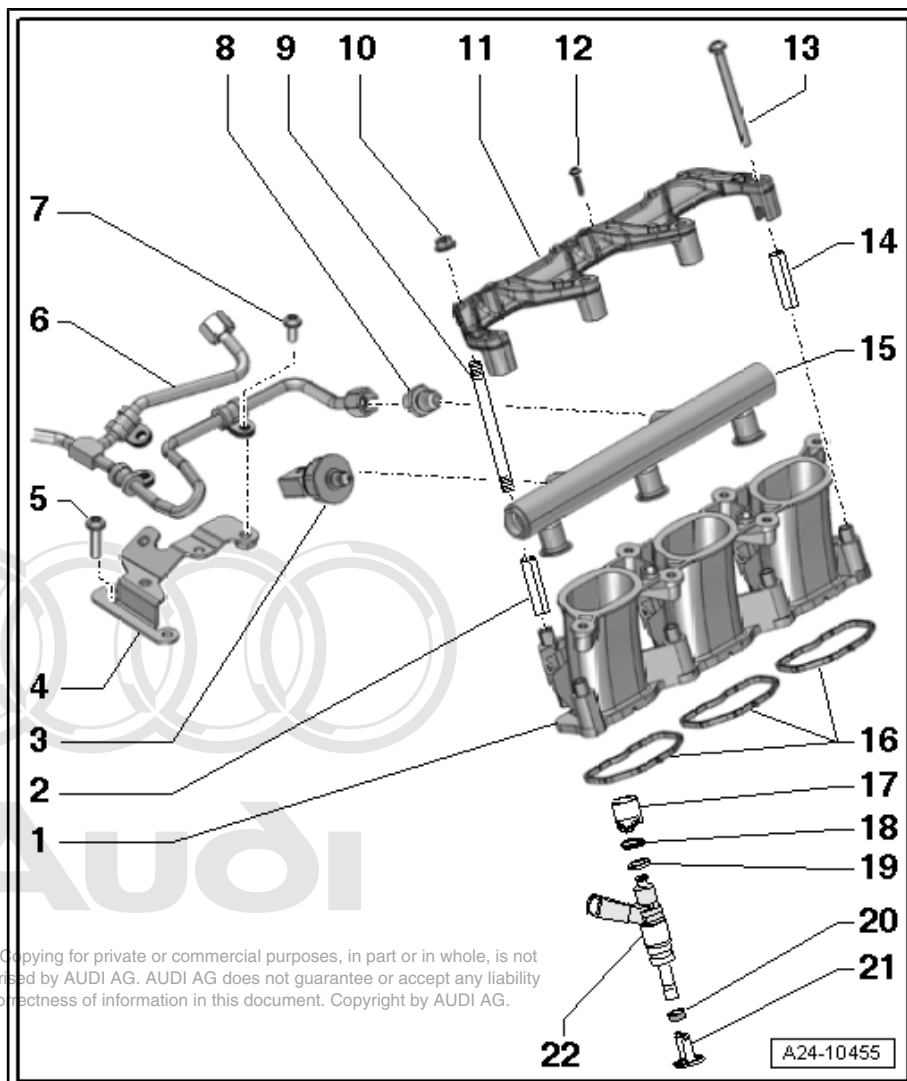



17 - Support ring

- Make sure it is correctly seated
- Via this support ring, the fuel rail exerts the force which holds the injector in the cylinder head.

18 - O-ring

- Renew
- Lubricate lightly with clean engine oil

19 - Spacer ring

- Renew if damaged

20 - Combustion chamber ring seal

- Renewing ⇒ „2.9 Removing and installing injectors“, page 24

21 - Radial compensation element

- Renew if damaged
- Clip onto support ring -item 17-

22 - Injector

Removing and installing ⇒ [page 24](#)

Installing high-pressure pipe

- Tighten union nut on high-pressure pipe hand-tight initially.
- Ensure that high-pressure pipe is not under tension.
- To tighten high-pressure pipe on fuel rail, use torque wrench -V.A.G 1331- with tool insert (open-end ring spanner, 17 mm) -V.A.G 1331/2- .
- Tighten union nut for high-pressure pipe to 27 Nm.

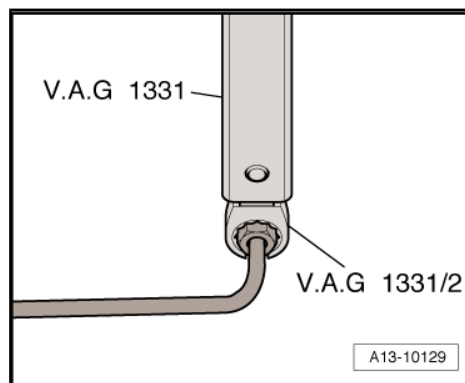

2.8 Removing and installing intake manifold (bottom section) with fuel rail

Special tools and workshop equipment required

- ◆ Torque wrench -V.A.G 1331-

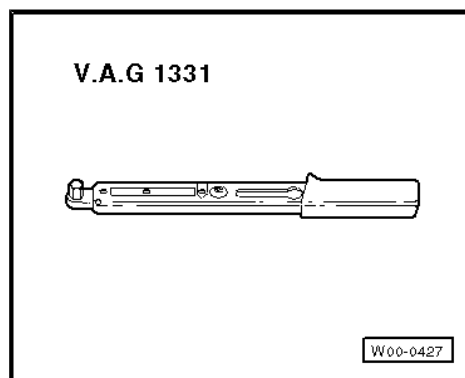

- ◆ Tool inserts -V.A.G 1331/2- , 17 mm

Removing

Proceed as follows:

 Note

The following description shows the removal and installation of the bottom section of the intake manifold (left-side). The procedure for the other side is more or less identical.

 **WARNING**

The fuel system operates at extremely high pressure. This can cause injury.

- ◆ *The fuel pressure in the high-pressure section of the injection system must be reduced to a residual pressure prior to opening the system.*
- ◆ *Wrap a clean cloth around the connection and carefully loosen the connection to allow the residual pressure to dissipate.*

- Reduce fuel pressure in high-pressure section of injection system ⇒ [page 2](#) .
- Remove intake manifold (top section) ⇒ [page 19](#) .

Protected by copyright. Copying for private or commercial purposes, in part or in whole, is not permitted without the express written permission of Audi AG. The correctness of information in this document. Copyright by AUDI AG.

- Unplug electrical connector at fuel pressure sender -G247- item 2-
- Remove union nut -1-.
- Remove bolts and nuts -arrows- and detach intake manifold (bottom section) with fuel rail.

 **Caution**

Risk of irreparable damage to engine.

- ◆ *Block off the intake ports with clean cloths to prevent small objects from dropping into the engine through the intake ports in the cylinder heads.*

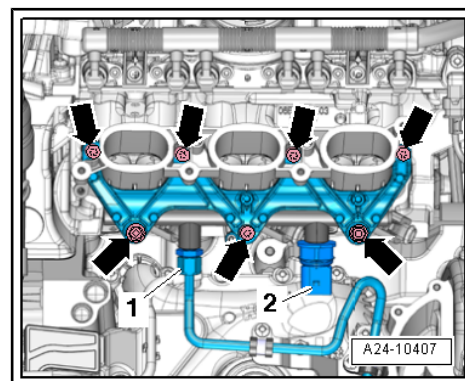

Installing

- Tightening torque ⇒ [page 21](#)

Installation is carried out in the reverse order; note the following:

 Note

- ◆ *Renew gaskets and O-rings.*
- ◆ *Lubricate O-rings of injectors lightly with clean engine oil.*
- Install intake manifold (bottom section) and press fuel rail evenly onto injectors.



- Tighten bolts and nuts -arrows- for intake manifold (bottom section) in diagonal sequence and in stages.
- Plug in electrical connector -2-.

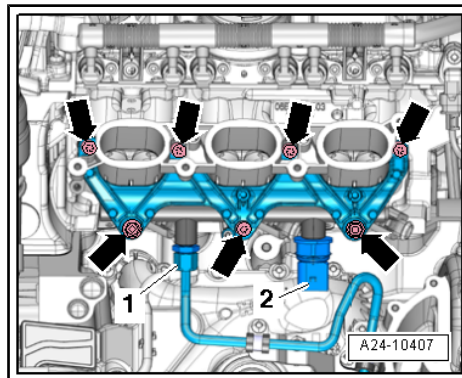

- Fit high-pressure pipe -1- on fuel rail => [page 22](#) .

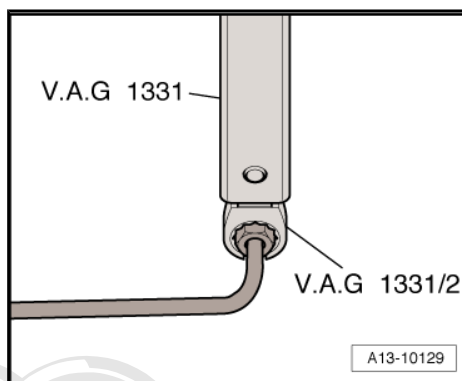

2.9 Removing and installing injectors

Special tools and workshop equipment required

- ◆ Tool set for FSI engines -T10133-

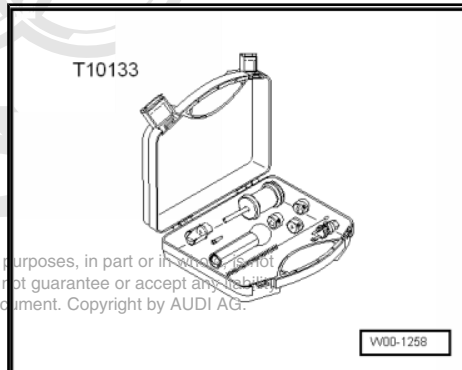

Protected by copyright. Copying for private or commercial purposes, in part or in full, is not permitted unless authorised by AUDI AG. AUDI AG does not guarantee or accept any liability with respect to the correctness of information in this document. Copyright by AUDI AG.

Injector - exploded view

- 1 - Radial compensation element (renew if damaged)
- 2 - Combustion chamber ring seal (teflon ring seal) - renew; when fitting, do not grease ring or use any other lubricant.
- 3 - Groove on injector
- 4 - Spacer ring (renew if damaged)
- 5 - O-ring (renew; apply thin coating of clean engine oil prior to installation)
- 6 - Support ring (via the support ring the fuel rail exerts force which secures injector in cylinder head)

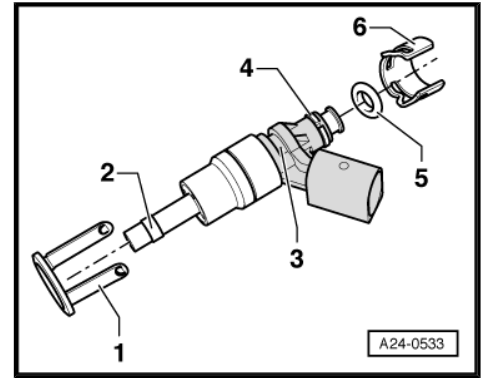

Removing

 **WARNING**

The fuel system operates at extremely high pressure. This can cause injury.

Protected by copyright. Copying for private or commercial purposes, in part or in whole, is not permitted. Liability for damage is not assumed.

- ◆ ***The fuel pressure in the high-pressure section of the injection system must be reduced to a residual pressure prior to opening the system.***
- ◆ ***Wrap a clean cloth around the connection and carefully loosen the connection to allow the residual pressure to dissipate.***

- Reduce fuel pressure in high-pressure section of injection system ⇒ [page 2](#) .
- Remove intake manifold (top section) ⇒ [page 19](#) .
- Remove corresponding intake manifold (bottom section) ⇒ [page 22](#) .

If injectors cannot be pulled out of cylinder head by hand, proceed as follows:

- Use a screwdriver to bend retainer tabs -1- of radial compensation element to side -arrow- and pull support ring -2- off injector.

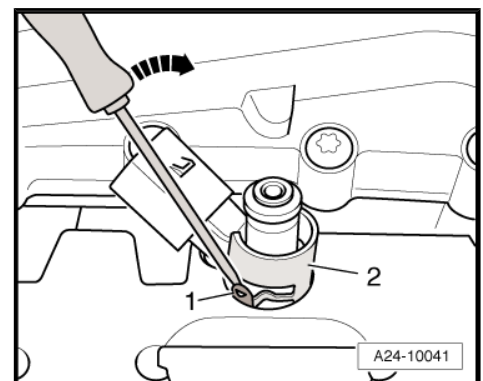

- Guide puller -T10133/2A- into groove on injector.
- Then attach removal tool -T10133/16- and pull out injector by turning bolt -1-.

Note

- ◆ ***When inserting the puller, there is a risk of destroying the radial compensation element due to the retainer tabs breaking.***
- ◆ ***The combustion chamber ring seal must always be renewed prior to reinstalling the injector.***

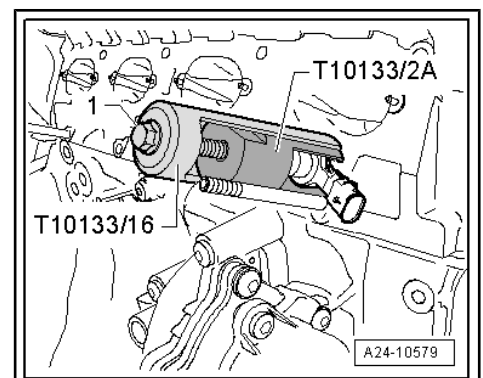



- Carefully remove old combustion chamber ring seal -arrow-. To do so, cut open ring using knife or prise open ring with small screwdriver and then pull off forwards.
- Take care not to damage groove on injector. The injector must be renewed if the groove is damaged.

Installing



Note

- ◆ *Renew combustion chamber ring seal and O-ring.*
- ◆ *Renew spacer ring if damaged.*
- ◆ *Lightly lubricate O-rings for injectors with clean engine oil.*
- ◆ *The injector pipes must be re-installed on the same cylinders.*

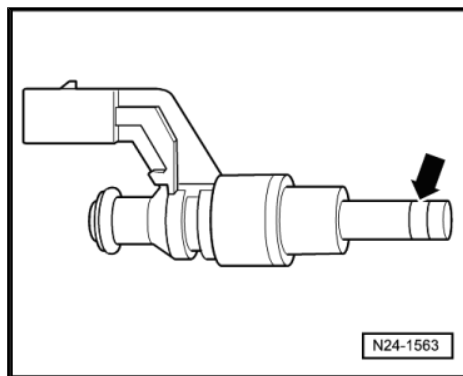

- Clip radial compensation element -1- into support ring -2-.
- When re-installing an injector, clean any combustion residue off groove for combustion chamber ring seal and injector stem with a clean cloth.

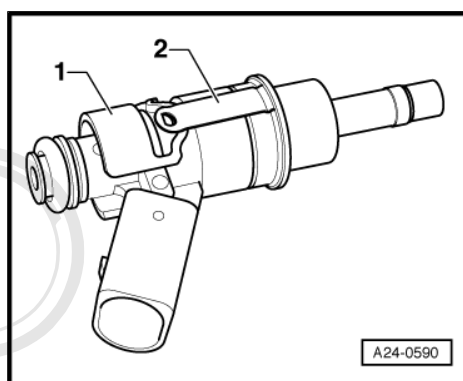

- Fit assembly cone -T10133/5- with new combustion chamber ring seal -1- onto injector -2-.

Protected by copyright. Copying for private or commercial purposes, in part or in whole, is not permitted unless authorised by AUDI AG. AUDI AG does not guarantee or accept any liability with respect to the correctness of information in this document. Copyright by AUDI AG.

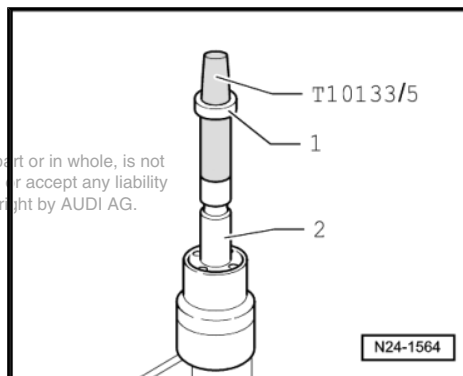

- Push combustion chamber ring seal onto assembly cone -T10133/6- as far as it will go using assembly sleeve -T10133/5-.
- Turn assembly sleeve -T10133/6- upside down and push combustion chamber ring seal into sealing ring groove.

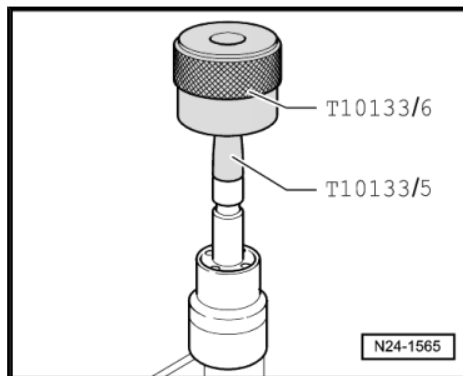

i Note

The combustion chamber ring seal is widened when it is pushed onto the injector. After pushing it on, it therefore has to be compressed again. This is done in two stages, as described below.

- Push calibration sleeve -T10133/7- onto injector as far as it will go and simultaneously turn it slightly (approx. 180°).
- Pull calibration sleeve -T10133/7- off again by turning it in the opposite direction.
- Push calibration sleeve -T10133/8- onto injector as far as it will go and simultaneously turn it slightly (approx. 180°).
- Pull calibration sleeve -T10133/8- off again by turning it in the opposite direction.
- Lubricate new O-ring lightly with clean engine oil before installing.

i Note

The combustion chamber ring seal must not be lubricated.

Renewing support ring

- Detach O-ring -3-.
- Cut open and detach support ring -2-.
- Detach spring element -1-.

- Fit locking plate -T10133/12- in place of spring element.
- Push support ring -1- onto assembly cone -T10133/13- and then fit assembly cone onto injector.
- Using calibration sleeve -T10133/14- , push support ring into first groove -arrow- on injector.
- Knurled side of calibration sleeve faces towards support ring.

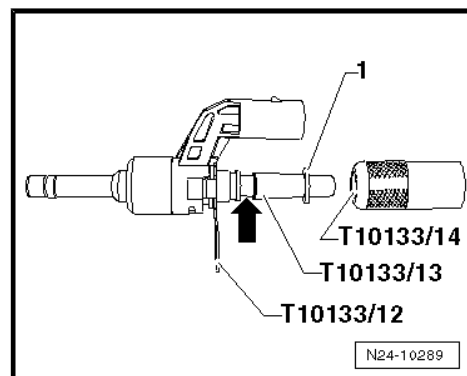
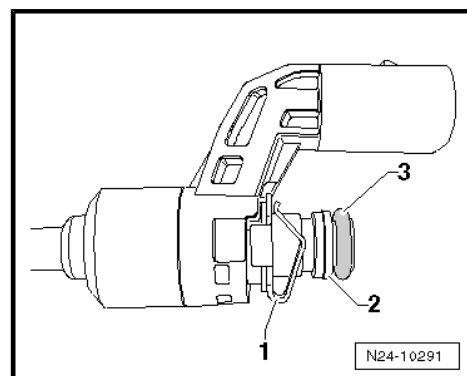
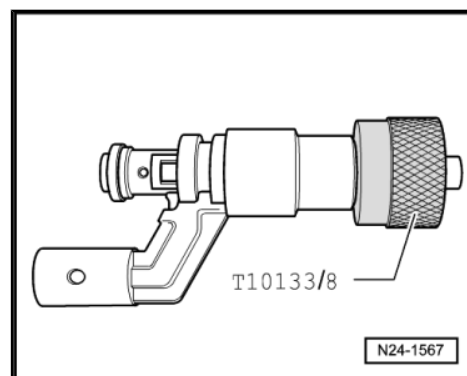
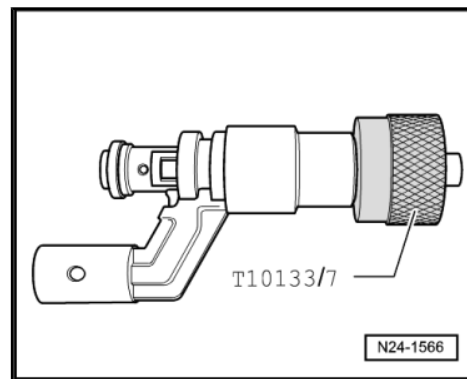



- Turn round calibration sleeve -T10133/14- and push on support ring until it makes contact with locking plate -T10133/12- -arrow-.
- Knurled side of calibration sleeve faces away from support ring.
- Take off calibration sleeve -T10133/14- .

Installing injectors

- Clean bore in cylinder head with nylon cylinder brush - T10133/4- .
- Push injector by hand as far as it will go into aperture in cylinder head (do not use oil or grease). Ensure that the injector is properly seated in the cylinder head.

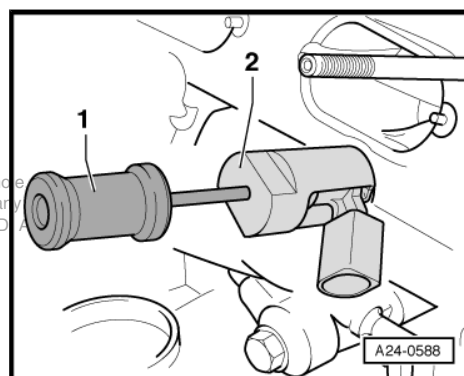
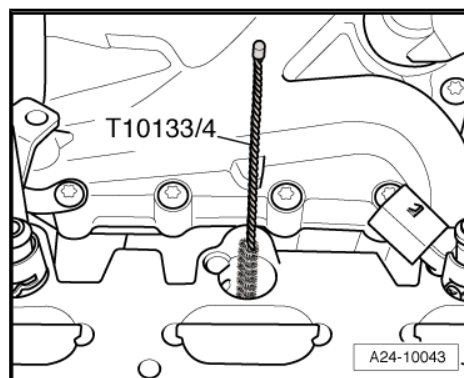
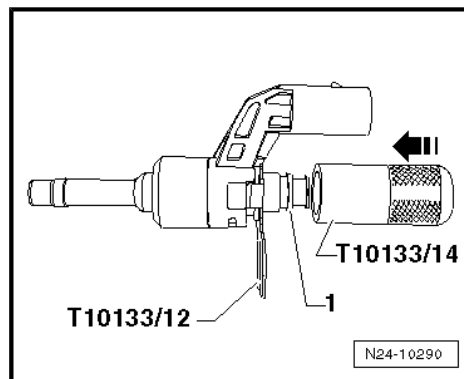

Note

◆ *It should be possible to insert injector easily. If necessary wait until the combustion chamber ring seal has contracted sufficiently.*

◆ *Note correct installation position and ensure that injectors are properly seated in cylinder head.*

◆ *If the injector cannot be pushed in by hand, use puller - T10133/2A- -2- with striker -T10133/3- to insert the injector.*

- Electrical connector of injector must engage in recess in cylinder head.

Installation is carried out in the reverse order; note the following:

- Install intake manifold (bottom section) ⇒ [page 22](#) .
- Install intake manifold (top section) ⇒ [page 19](#) .

2.10 Checking fuel pressure and residual pressure (up to high-pressure fuel pump)

Special tools and workshop equipment required

- ◆ K-Jetronic pressure tester -V.A.G 1318-

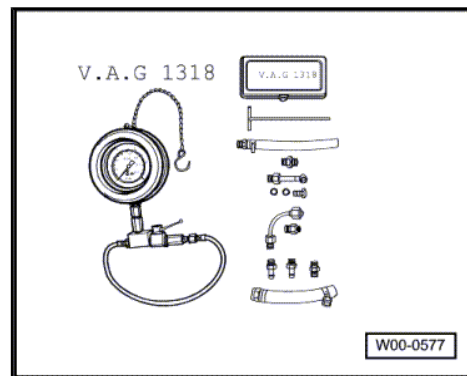

- ◆ Adapter set -V.A.G 1318/10-12- and adapter -V.A.G 1318/15-

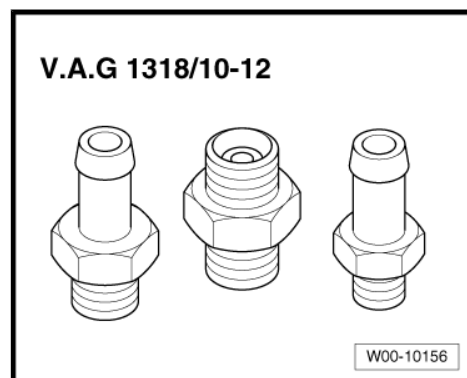

- ◆ Remote control -V.A.G 1348/3A- for V.A.G 1348 with adapter cable -V.A.G 1348/3-3-

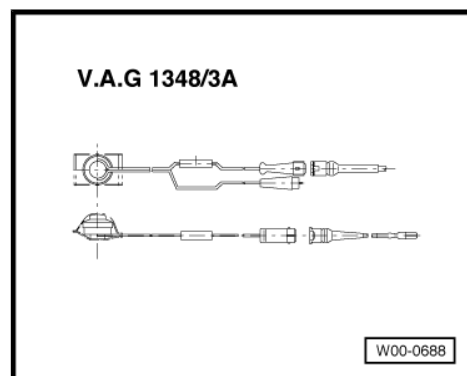

- ◆ Fuel-resistant measuring container

Procedure

- Battery voltage at least 12.5 V.
- Fuel filter OK.
- Fuel tank at least 1/4 full.
- Fuel pump control unit -J538- OK; check in "Guided Fault Finding" mode using vehicle diagnostic, testing and information system -VAS 5051B- .
- Ignition off.



Audi



WARNING

Observe safety precautions ⇒ [page 1](#) .

- Remove right luggage compartment side trim cover -arrows-.

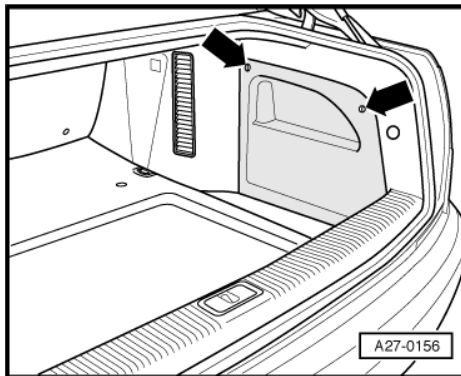

- Remove cover -2- over battery.



Note

Disregard -item 1-.



Protected by copyright. Copying for private or commercial purposes, in part or in whole, is not permitted unless authorised by AUDI AG. AUDI AG does not guarantee or accept any liability with respect to the correctness of information in this document. Copyright by AUDI AG.

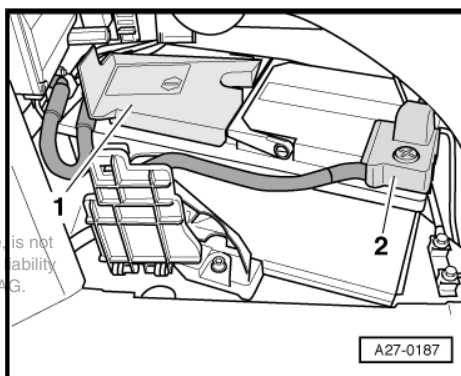

- Remove luggage compartment floor lining.
- Unscrew bolts -arrows- and remove cover for flange on fuel tank (left-side).

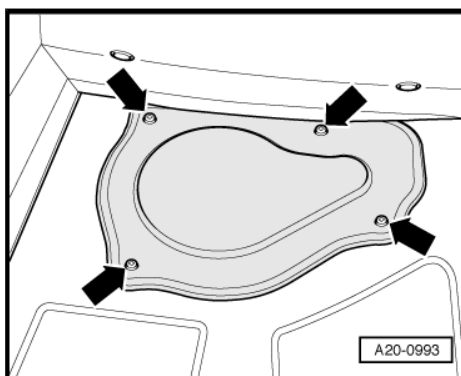

- Unplug electrical connector -2- on flange (left-side).



Note

Disregard -item 1-.

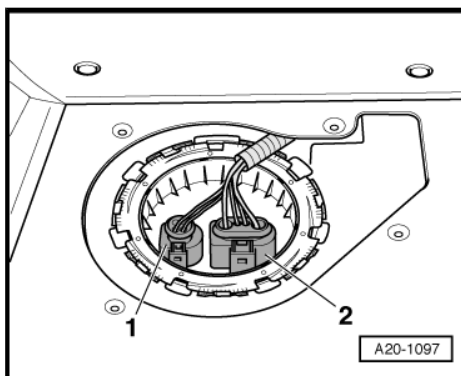

- Unscrew bolts -arrows- and remove cover for flange (right-side).

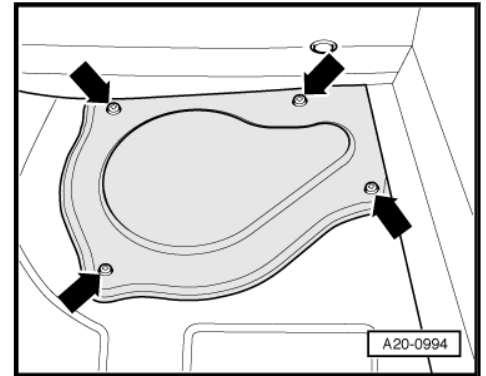

- Unplug electrical connector -2- on flange (right-side).

 **Note**

Disregard -item 1-.

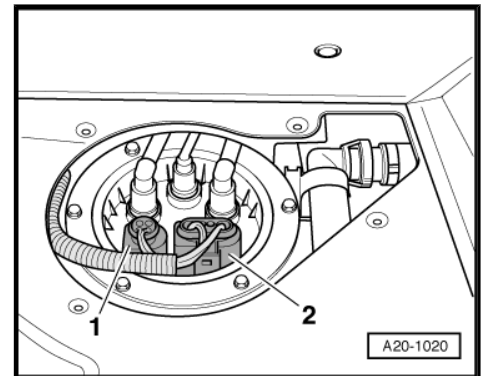

- Connect remote control -V.A.G 1348/3A- for V.A.G 1348 with adapter cable -V.A.G 1348/3-3- to contact -4- (earth) of fuel delivery unit (left-side) and fuel delivery unit (right-side) using test leads from auxiliary measuring set -V.A.G 1594C- .
- Move switch of remote control -V.A.G 1348/3A- for V.A.G 1348 to front of engine compartment.
- Connect crocodile clip to earth point in engine compartment.
- Connect contact -1- (positive) of fuel delivery unit (left-side) and fuel delivery unit (right-side) to battery „+“ via an improvised auxiliary lead. For safety reasons an in-line fuse -A- (10 A) must be connected into the lead.
- Remove filler cap from fuel filler neck.

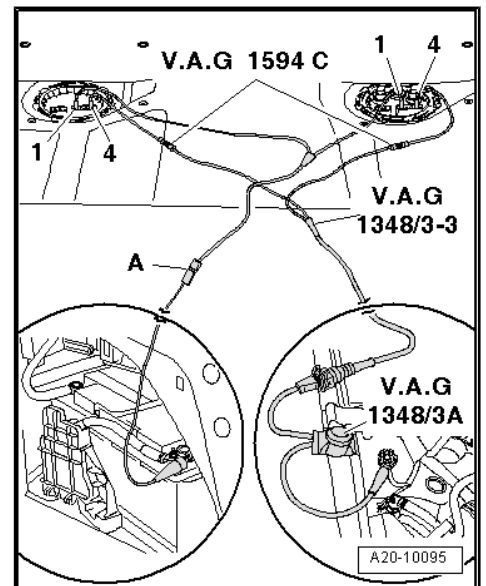

Audi

Protected by copyright. Copying for private or commercial purposes, in part or in whole, is not permitted unless authorised by AUDI AG. AUDI AG does not guarantee or accept any liability with respect to the correctness of information in this document. Copyright by AUDI AG.



- Pull off rear engine cover panel -top arrows-.

 **WARNING**

The fuel system operates at extremely high pressure. This can cause injury.

- ◆ *The fuel pressure in the high-pressure section of the injection system must be reduced to a residual pressure prior to opening the system.*
- ◆ *Wrap a clean cloth around the connection and carefully loosen the connection to allow the residual pressure to dissipate.*

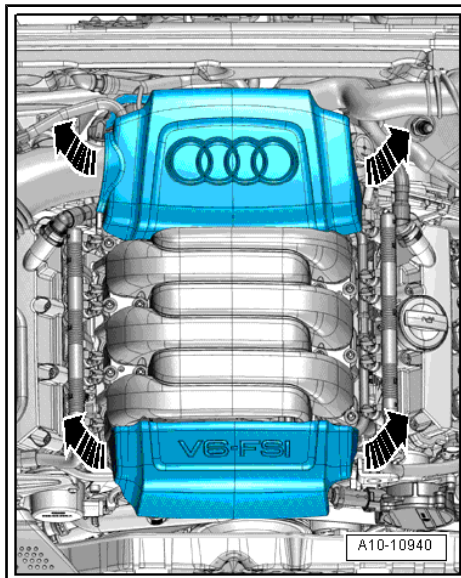

- Reduce fuel pressure in high-pressure section of injection system => [page 2](#) .
- Remove air duct from air cleaner.
- Unscrew bolts -arrows- and remove guard plate -1-.

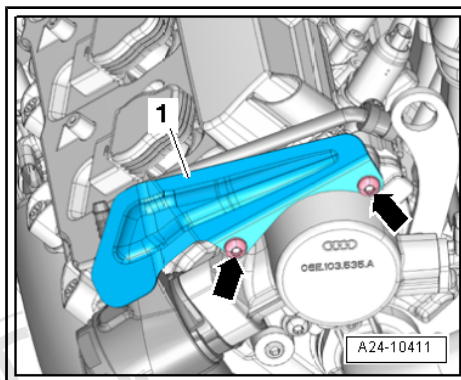

- Detach fuel supply hose from high-pressure fuel pump -arrow- and move clear.

Checking fuel pressure

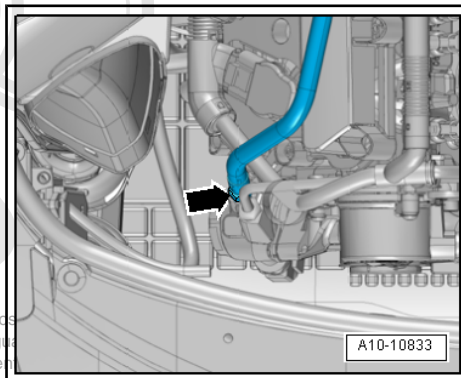

Protected by copyright. Copying for private or commercial purposes is not permitted unless authorised by AUDI AG. AUDI AG does not give any warranty with respect to the correctness of information in this document.

- Connect K-Jetronic pressure tester -V.A.G 1318- with adapters -V.A.G 1318/11- and -V.A.G 1318/15- to fuel line.
- Connect extension hose -arrow- to pressure tester and hold end of hose in measuring container.
- Open cut-off valve on pressure tester.
 - Lever points in direction of flow.
- Bleed fuel system by pressing remote control briefly.

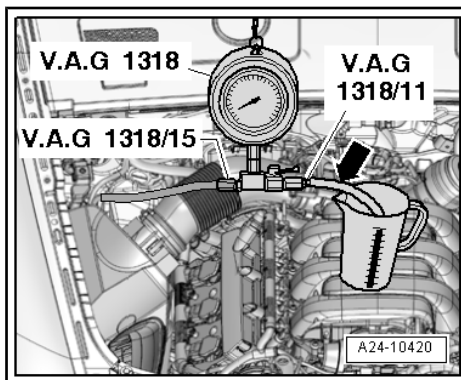

- Close cut-off valve on pressure tester.
- Lever is at right angle to direction of flow -arrow-.
- Press switch on remote control until pressure tester shows no further increase in pressure.
- Specification: approx. 6 bar

If specification is not obtained:

- Check delivery rate of fuel pump ⇒ Rep. gr. 20 .

Checking residual pressure

- Check for leaks and check residual pressure by watching pressure drop on pressure tester.
- After 10 minutes pressure should still be at least 3 bar.

If the residual pressure drops below 3 bar:

- ◆ Check union between pressure gauge and fuel line for leaks.
- ◆ Test pressure gauge for leaks.
- ◆ Check fuel lines and their connections for leaks.
- ◆ Renew fuel filter with integrated fuel pressure regulator ⇒ Rep. gr. 20 .
- ◆ Renew fuel pump ⇒ Rep. gr. 20 .

Assembling

- Tightening torque ⇒ [page 34](#)

Installation is carried out in the reverse order; note the following:



WARNING

The fuel system operates at extremely high pressure. This can cause injury.

- ◆ *Before removing the pressure tester, release the fuel pressure by opening the cut-off valve. Hold a container under the connection.*

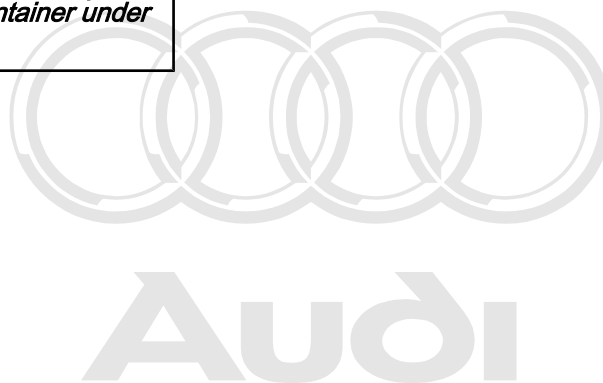
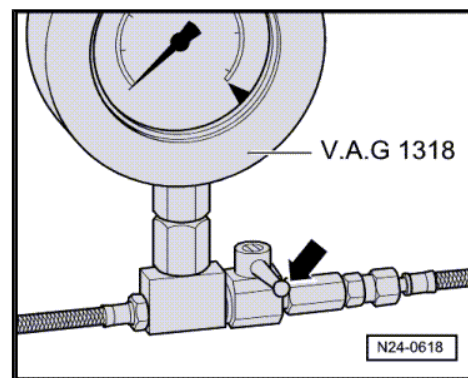

Protected by copyright. Copying for private or commercial purposes, in part or in whole, is not permitted unless authorised by AUDI AG. AUDI AG does not guarantee or accept any liability with respect to the correctness of information in this document. Copyright by AUDI AG.



2.11 High-pressure fuel pump - exploded view

1 - Fuel pressure sender for low pressure -G410-

- 15 Nm

2 - Seal

- Renew

3 - Bolt

- Hand-tighten in diagonal sequence, then tighten to 5 Nm
- Final torque: 20 Nm
- Do not tilt high-pressure fuel pump

4 - High-pressure fuel pump

- With fuel metering valve -N290-
- To loosen and tighten fuel pipes, counterhold at fuel pipe connection
- Re-tighten threaded connections for fuel pipes before installing fuel pipes
- Removing and installing ⇒ [page 35](#)
- Do not dismantle

5 - Threaded connection

- 27 Nm

6 - Hose clip

- Renew; use correct type of hose clips (as original equipment) ⇒ Parts catalogue

7 - Fuel supply hose

- Low-pressure section

8 - High-pressure fuel pipe

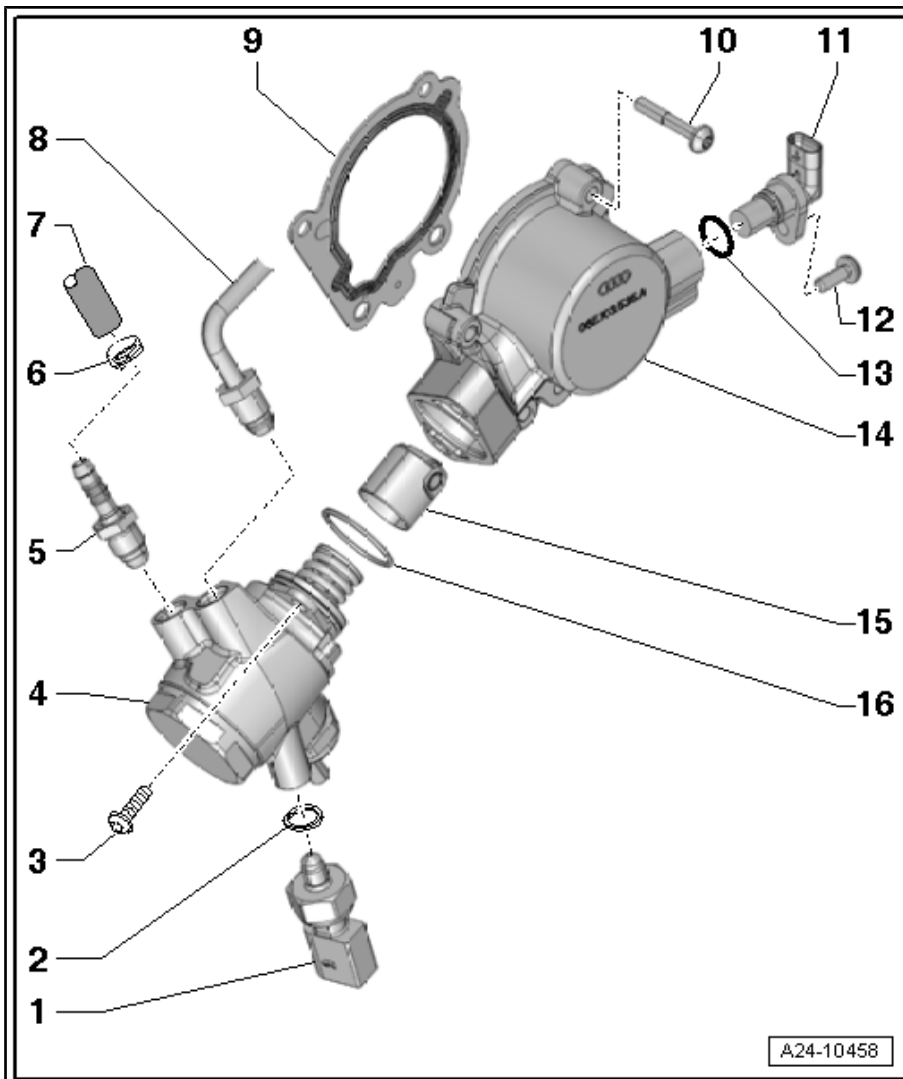

! WARNING

The fuel system operates at extremely high pressure. This can cause injury. The pressure in the high-pressure section of the injection system must be reduced to a residual pressure prior to opening the system.

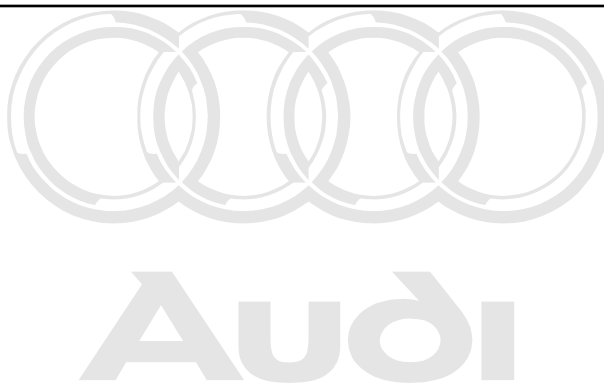

Protected by copyright. Copying for private or commercial purposes, in part or in whole, is not permitted unless authorised by AUDI AG. AUDI AG does not guarantee or accept any liability with respect to the correctness of information in this document. Copyright by AUDI AG.

- Reducing fuel pressure in high-pressure section of injection system ⇒ [page 2](#)
- To loosen and tighten union nut, counterhold at connection on high-pressure fuel pump
- Before installation, re-tighten connection on high-pressure fuel pump
- Installing ⇒ [page 35](#)

9 - Gasket

- Renew

10 - Bolt

- 9 Nm

11 - Hall sender -G40-

12 - Bolt

- 9 Nm

13 - O-ring

- Renew
- Lubricate lightly with clean engine oil before installing

14 - Housing

15 - Roller tappet

- Lubricate lightly with clean engine oil before installing

16 - O-ring

- Renew
- Lubricate lightly with clean engine oil before installing

Guard plate for high-pressure pipe - tightening torque

- Tighten bolts -arrows- for guard plate -1- to 9 Nm.

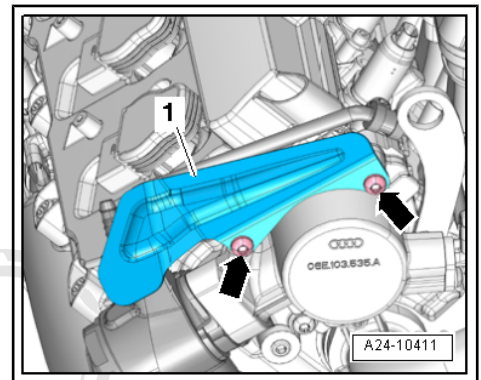

Installing high-pressure pipe

- Tighten union nut on high-pressure pipe hand-tight initially.
- Ensure that high-pressure pipe is not under tension.
- To tighten union of high-pressure pipe at high-pressure fuel pump, use torque wrench -V.A.G 1331- with ratchet -V.A.G 1331/1- and socket, 14 mm -3150- .
- Tighten union nut for high-pressure pipe to 27 Nm.

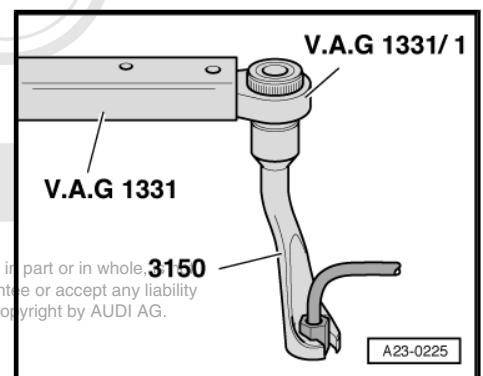

2.12 Removing and installing high-pressure pump

Special tools and workshop equipment required



- ◆ Torque wrench -V.A.G 1331-

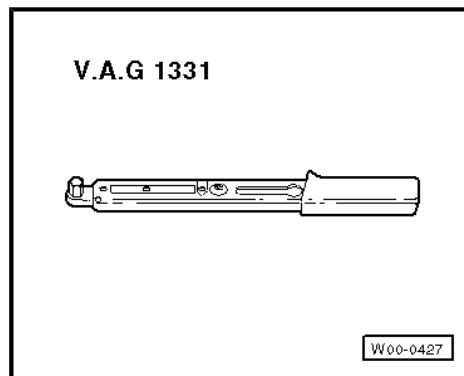

- ◆ Ratchet -V.A.G 1331/1-

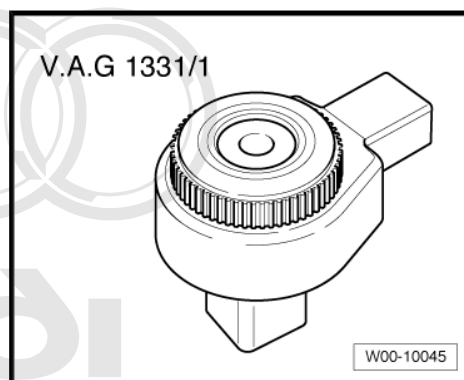

- ◆ Socket, 14 mm -3150-

Protected by copyright. Copying for private or commercial purposes, in part or in whole, is not permitted unless authorised by AUDI AG. AUDI AG does not guarantee or accept any liability with respect to the correctness of information in this document. Copyright by AUDI AG.

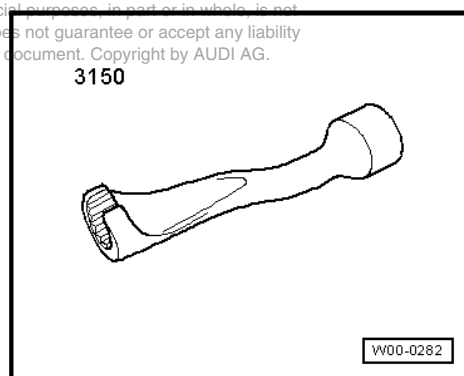

Removing



WARNING

The fuel system operates at extremely high pressure. This can cause injury.

- ◆ *The fuel pressure in the high-pressure section of the injection system must be reduced to a residual pressure prior to opening the system.*
- ◆ *Wrap a clean cloth around the connection and carefully loosen the connection to allow the residual pressure to dissipate.*

- Reduce fuel pressure in high-pressure section of injection system ⇒ [page 2](#).
- Remove air duct from air cleaner.

- Unscrew bolts -arrows- and remove guard plate -1-.

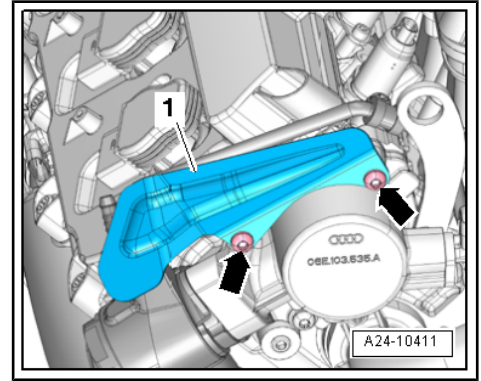

- Unplug electrical connectors -1- and -6-.
- Unscrew connections -2- and -5-.
- Remove bolts -3- and -4- from retaining clips.
- Remove bolts -arrows- and lift high-pressure pipe carefully.

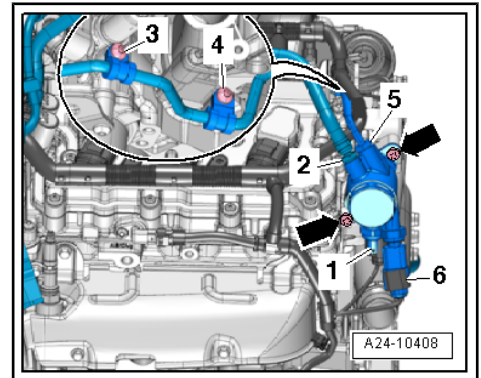

i Note

Do not bend pipes to a different shape.

- Detach high-pressure pump with roller tappet.

Installing

Installation is carried out in the reverse order; note the following:

i Note

- ◆ *Renew O-ring.*
- ◆ *The connections of the high-pressure pipe must not be damaged.*
- ◆ *Do not attempt to bend high-pressure pipe to a different shape.*

- Only lift high-pressure pipe slightly to fit high-pressure pump.
- Check roller tappet -1- for damage and renew if necessary.
- Lightly lubricate roller tappet with oil and insert it so that lug -arrow A- slides into guide notch -arrow B-.
- Rotate crankshaft in direction of engine rotation by turning bolt for vibration damper, and at the same time press roller tappet into vacuum pump until it reaches its lowest point.
- Fit high-pressure pump in vacuum pump.
- Tighten bolts hand-tight.
- Now tighten bolts in diagonal sequence to specified torque.

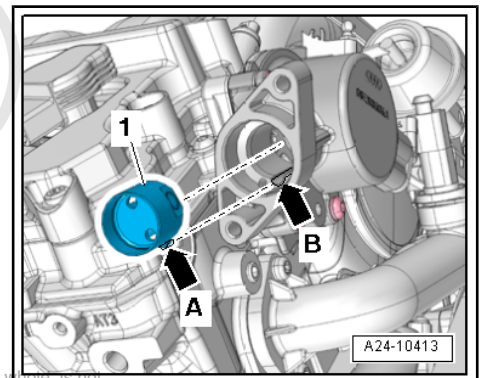

- Tightening torque: refer to exploded view of high-pressure fuel pump => [page 34](#)
- ... is not permitted unless authorised by AUDI AG. AUDI AG does not guarantee or accept any liability with respect to the correctness of information in this document. Copyright by AUDI AG.

- Install high-pressure pipe ⇒ [page 35](#) .

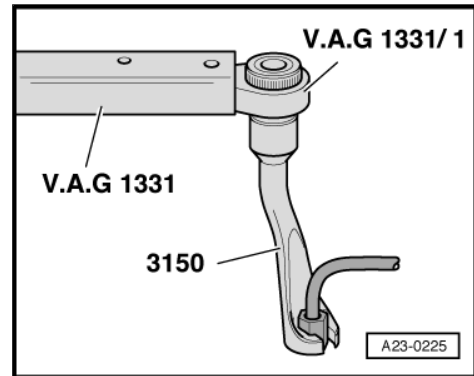

2.13 Bleeding fuel system

In order to prevent damage to the catalytic converter, the fuel system must be bled after working on the fuel pipes or the fuel filter.

Procedure

- Start engine and let it run at moderate speed for several minutes and then switch off.



Note

To begin with, the engine may not run smoothly due to air in fuel system.

- Check fuel system for leaks.
- Connect vehicle diagnostic tester.
- Start „self-diagnosis“ mode, interrogate event memory and erase if necessary.
- After completing the repair, road-test the vehicle. Accelerate with full throttle at least once. Then inspect fuel system for leaks again.
- If event memory has been erased, start „Guided Functions“ mode and generate readiness code in engine control unit.

2.14 Lambda probes - overview

Electrical connectors for Lambda probes (plenum chamber partition panel)

- 1 - To Lambda probe after catalytic converter -G130-
- 2 - To Lambda probe -G39-
- 3 - To Lambda probe 2 -G108-
- 4 - To Lambda probe 2 after catalytic converter -G131-

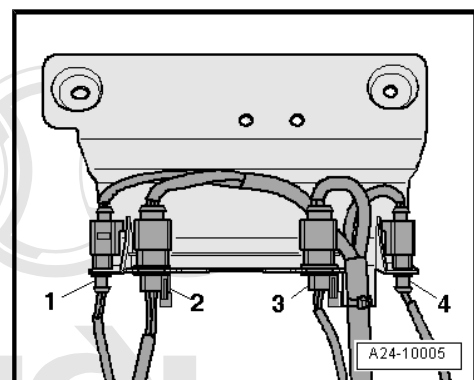

Lambda probes, cylinder bank 1 (right-side)

- 1 - Lambda probe after catalytic converter -G130-
- 2 - Lambda probe -G39-

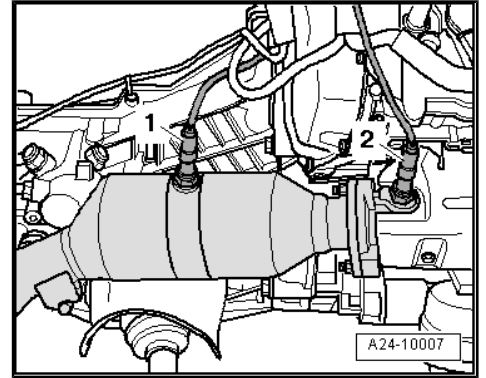

Lambda probes, cylinder bank 2 (left-side)

- 1 - Lambda probe 2 -G108-
- 2 - Lambda probe 2 after catalytic converter -G131-

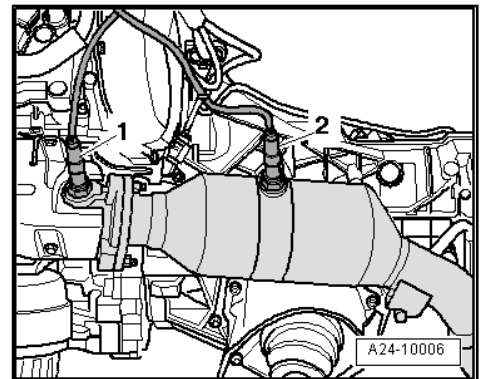

i Note

- ◆ *Threads of new Lambda probes are already coated with assembly paste; the paste must not get into the slots on the probe body.*
- ◆ *In the case of a used Lambda probe grease only the thread with high-temperature paste. The paste must not get into the slots on the Lambda probe body. High-temperature paste → Parts catalogue*
- ◆ *When installing, it is important to re-attach the Lambda probe wiring at the same locations to prevent it from coming into contact with the exhaust pipe.*

- Tightening torque: 55 Nm

Removing and installing Lambda probe -G39- ⇒ [page 39](#)

Removing and installing Lambda probe after catalytic converter -G130- ⇒ [page 41](#)

Removing and installing Lambda probe 2 -G108- ⇒ [page 43](#)

Removing and installing Lambda probe 2 after catalytic converter -G131- ⇒ [page 45](#)

2.15 Removing and installing Lambda probe -G39- before catalytic converter - bank 1 (right-side)

Special tools and workshop equipment required

- ◆ Lambda probe open ring spanner set -3337-

protected by copyright. Copying for private or commercial purposes, in part or in whole, is not permitted unless authorised by AUDI AG. AUDI AG does not guarantee or accept any liability with respect to the correctness of information in this document. Copyright by AUDI AG.

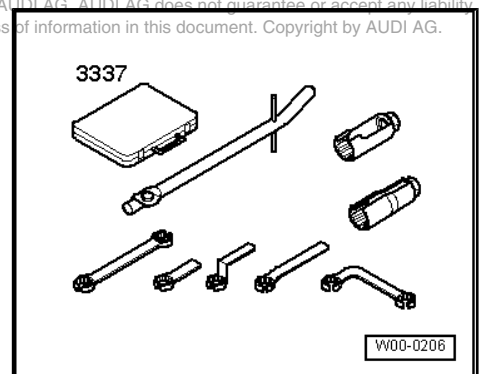



Removing

- Pull off rear engine cover panel -top arrows-.



Note

Fit all cable ties in the original positions when installing.

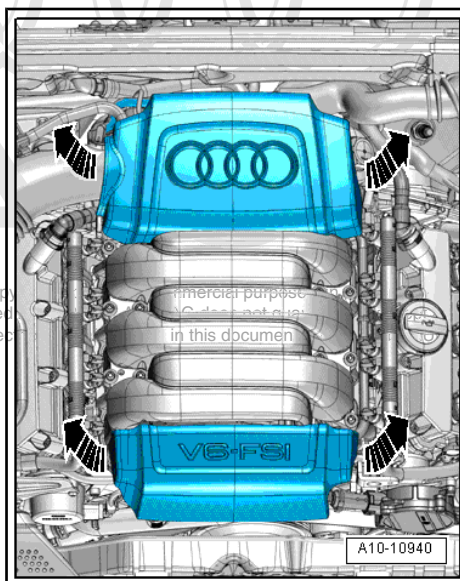

- Disconnect non-return valve -2- from connection on air hose.
- Unclip vacuum line -1- and fuel line -3- from retainer on air hose.
- Release hose clips -arrows- and remove air hose.

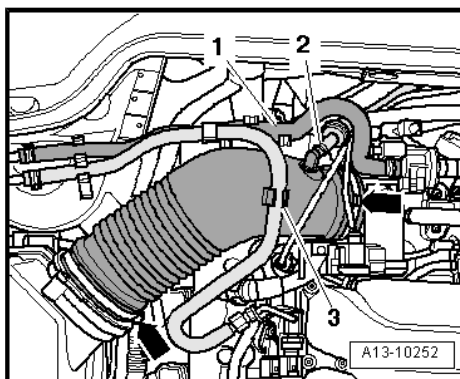

- Detach vacuum hose -2-.
- Unscrew bolts -arrows- and remove air cleaner housing.



Note

Disregard -item 1-.

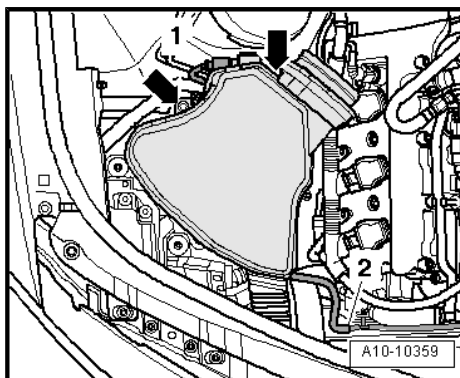

- Unplug electrical connector -2- for Lambda probe -G39- and move wiring clear.



Note

Disregard -items 1, 3 and 4-.

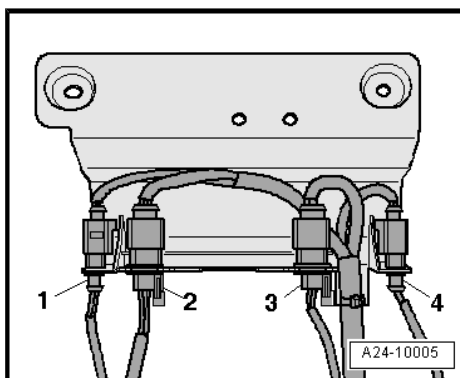

- Unscrew Lambda probe -2- using tool from Lambda probe open ring spanner set -3337- .

 **Note**

For illustration purposes, the installation position is shown with the engine removed.

Installing

Installation is carried out in the reverse order; note the following:

 **Note**

Protected by copyright. Copying for private or commercial purposes, in part or in whole, is not permitted unless authorised by AUDI AG. AUDI AG does not guarantee or accept any liability with respect to the accuracy of the information in this document. Copyright by AUDI AG.

- ◆ *Threads of new Lambda probes are already coated with assembly paste; the paste must not get into the slots on the probe body.*
- ◆ *In the case of a used Lambda probe grease only the thread with high-temperature paste. The paste must not get into the slots on the Lambda probe body. High-temperature paste ⇒ Parts catalogue*
- ◆ *When installing, it is important to re-attach the Lambda probe wiring at the same locations to prevent it from coming into contact with the exhaust pipe.*
- Tightening torques for Lambda probe: refer to Lambda probes - overview ⇒ [page 38](#)

2.16 Removing and installing Lambda probe after catalytic converter -G130- - bank 1 (right-side)

Special tools and workshop equipment required

- ◆ Lambda probe open ring spanner set -3337-

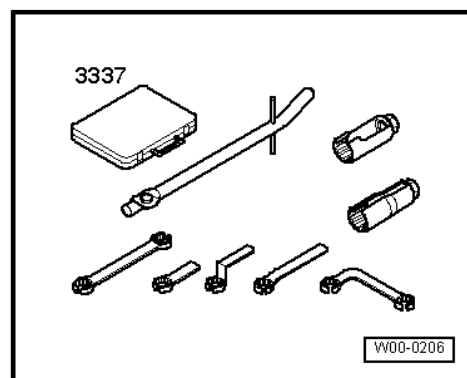
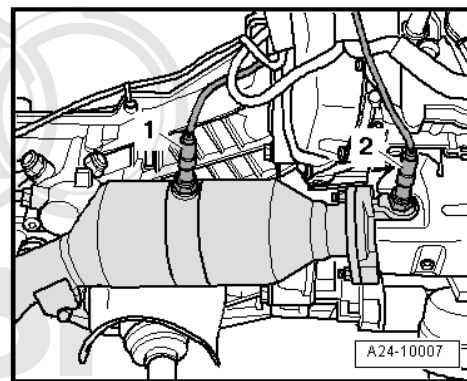



Removing

- Pull off rear engine cover panel -top arrows-.



Note

Fit all cable ties in the original positions when installing.

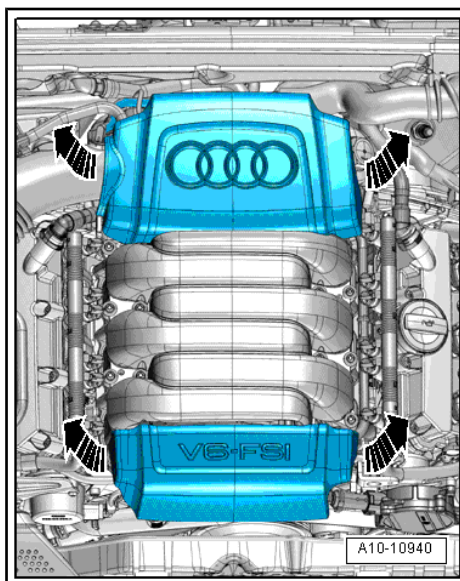

- Disconnect non-return valve -2- from connection on air hose.
- Unclip vacuum line -1- and fuel line -3- from retainer on air hose.
- Release hose clips -arrows- and remove air hose.

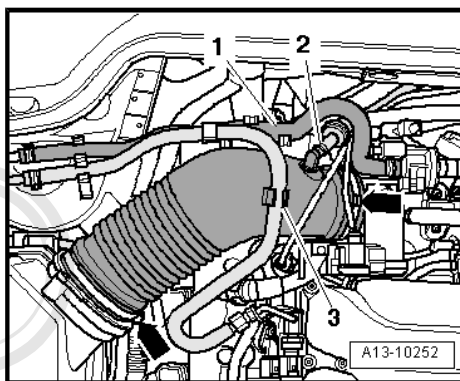

- Unplug electrical connector -1- for Lambda probe after catalytic converter -G130- and move wiring clear.



Note

Disregard -items 2, 3 and 4-

Protected by copyright. Copying for private or commercial purposes, in part or in whole, is prohibited unless authorised by AUDI AG. AUDI AG does not guarantee or accept any liability with respect to the correctness of information in this document. Copyright by AUDI AG.

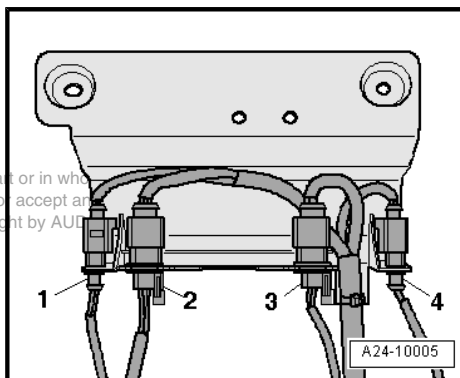

- Unscrew Lambda probe -1- using tool from Lambda probe open ring spanner set -3337- .

 **Note**

For illustration purposes, the installation position is shown with the engine removed.

Installing

Installation is carried out in the reverse order; note the following:

 **Note**

- ◆ *Threads of new Lambda probes are already coated with assembly paste; the paste must not get into the slots on the probe body.*
- ◆ *In the case of a used Lambda probe grease only the thread with high-temperature paste. The paste must not get into the slots on the Lambda probe body. High-temperature paste ⇒ Parts catalogue*
- ◆ *When installing, it is important to re-attach the Lambda probe wiring at the same locations to prevent it from coming into contact with the exhaust pipe.*

- Tightening torques for Lambda probe: refer to Lambda probes - overview ⇒ [page 38](#)

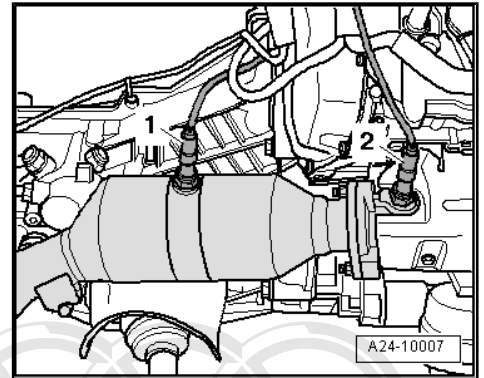

Protected by copyright. Copying for private or commercial purposes, in part or in whole, is not permitted unless authorised by AUDI AG. AUDI AG does not guarantee or accept any liability with respect to the correctness of information in this document. Copyright by AUDI AG.

2.17 Removing and installing Lambda probe 2 -G108- before catalytic converter - bank 2 (left-side)

Special tools and workshop equipment required

- ◆ Lambda probe open ring spanner set -3337-

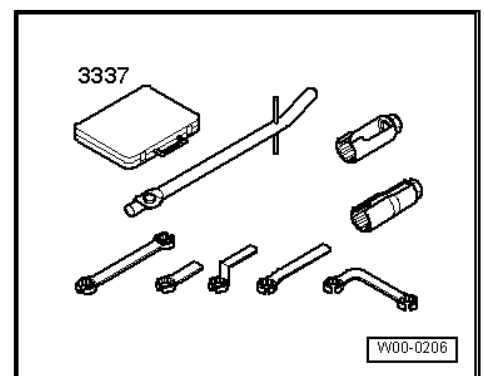



Removing

- Pull off rear engine cover panel -top arrows-.



Note

Fit all cable ties in the original positions when installing.

- Drain coolant ⇒ Rep. gr. 19 .

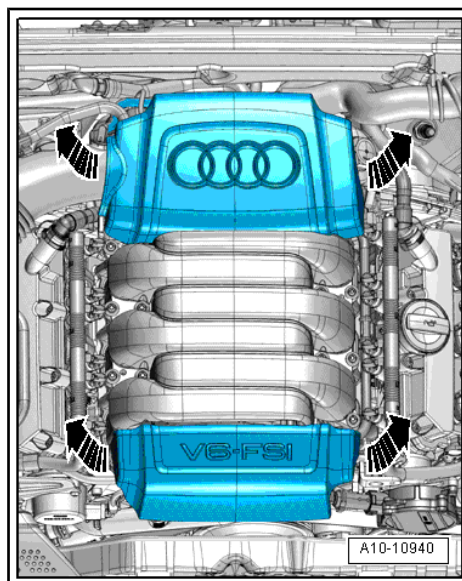

- Disconnect hoses -1- and -2- and coolant hose (bottom) from coolant expansion tank.
- Detach electrical connector at coolant shortage indicator switch -F66- on coolant expansion tank.
- Remove bolts -arrows- and remove coolant expansion tank.

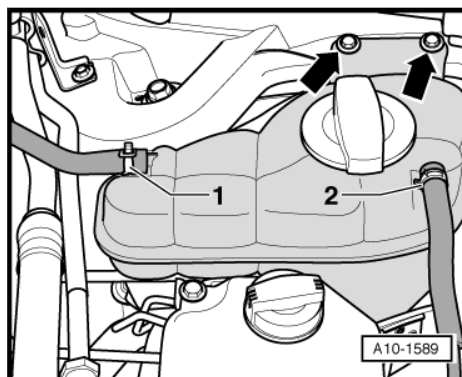

- Remove bolts -arrows- and unplug electrical connectors at ignition coils.
- Unplug electrical connector -4- for Hall sender 4 -G301- and move wiring clear.

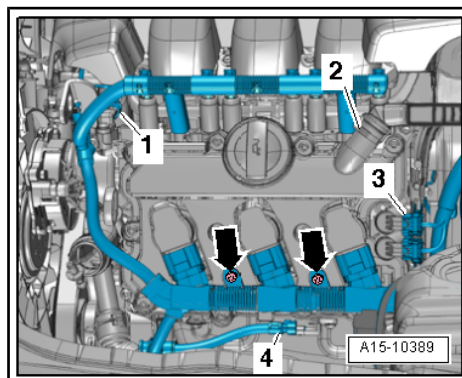

Note

Disregard -items 1, 2 and 3-.

- Unplug electrical connector -3- for Lambda probe 2 -G108- and move wiring clear.

Protected by copyright. Copying for private or commercial purposes, in part or in whole, is not permitted unless authorised by AUDI AG. AUDI AG does not guarantee or accept any liability with respect to the correctness of information in this document. Copyright by AUDI AG.



Note

Disregard -items 1, 2 and 4-.

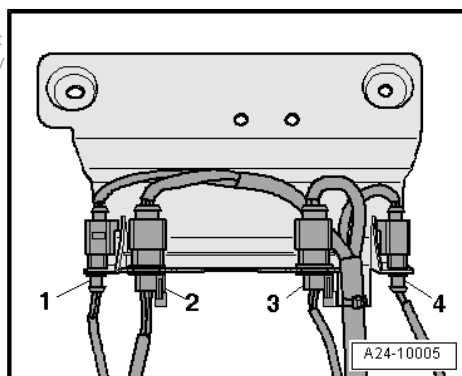

- Unscrew Lambda probe -1- using tool from Lambda probe open ring spanner set -3337- .

 **Note**

For illustration purposes, the installation position is shown with the engine removed.

Installing

Installation is carried out in the reverse order; note the following:

 **Note**

- ◆ *Threads of new Lambda probes are already coated with assembly paste; the paste must not get into the slots on the probe body.*
- ◆ *In the case of a used Lambda probe grease only the thread with high-temperature paste. The paste must not get into the slots on the Lambda probe body. High-temperature paste → Parts catalogue*
- ◆ *When installing, it is important to re-attach the Lambda probe wiring at the same locations to prevent it from coming into contact with the exhaust pipe.*

- Tightening torques for Lambda probe: refer to Lambda probes - overview ⇒ [page 38](#)

- Fill up with coolant ⇒ Rep. gr. 19 .

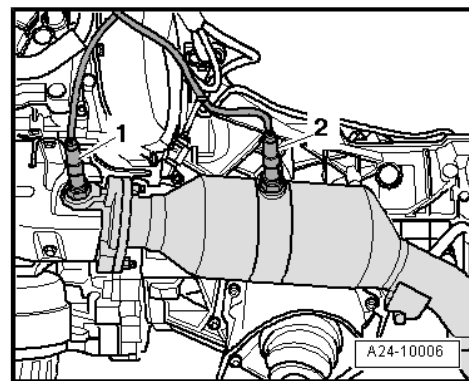

2.18 Removing and installing Lambda probe 2 after catalytic converter -G131- - bank 2 (left-side)

Protected by copyright. Copying for private or commercial purposes, in part or in whole, is not permitted without the written permission of AUDI AG. AUDI AG does not guarantee or accept any liability with respect to the correctness of information in this document. Copyright by AUDI AG.

Special tools and workshop equipment required

- ◆ Lambda probe open ring spanner set -3337-

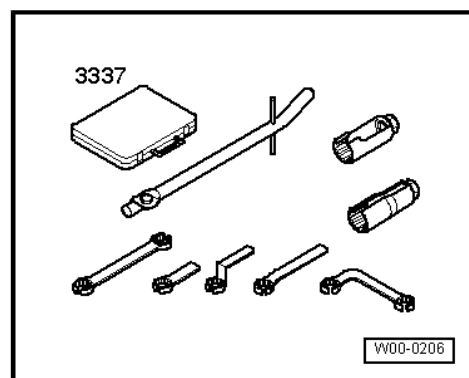



Removing

- Pull off rear engine cover panel -top arrows-.



Note

Fit all cable ties in the original positions when installing.

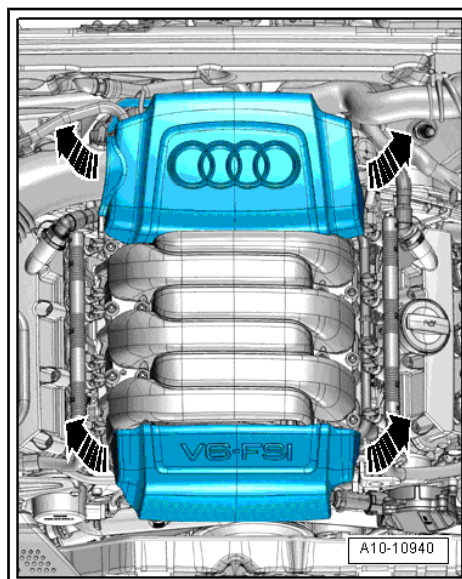

- Unplug electrical connector -4- for Lambda probe 2 after catalytic converter -G131- .



Note

Disregard -items 1, 2 and 3-.

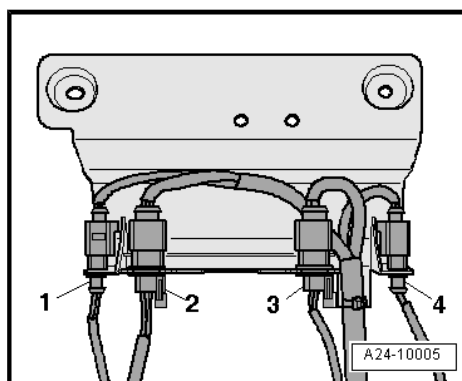

Protected by copyright. Copying for private or commercial purposes, in part or in whole, is not permitted unless authorised by AUDI AG. AUDI AG does not guarantee or accept any liability with respect to the correctness of information in this document. Copyright by AUDI AG.

- Unscrew Lambda probe -2- using tool from Lambda probe open ring spanner set -3337- .

 **Note**

For illustration purposes, the installation position is shown with the engine removed.

Installing

Installation is carried out in the reverse order; note the following:

 **Note**

- ◆ *Threads of new Lambda probes are already coated with assembly paste; the paste must not get into the slots on the probe body.*
- ◆ *In the case of a used Lambda probe grease only the thread with high-temperature paste. The paste must not get into the slots on the Lambda probe body. High-temperature paste ⇒ Parts catalogue*
- ◆ *When installing, it is important to re-attach the Lambda probe wiring at the same locations to prevent it from coming into contact with the exhaust pipe.*

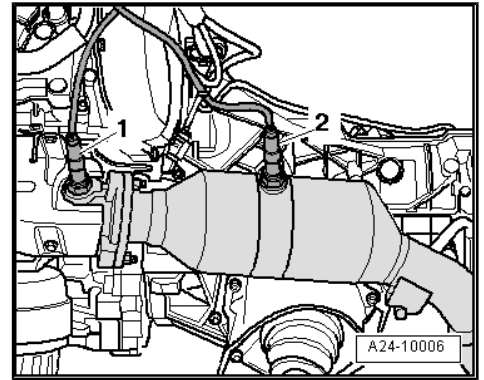

- **Tightening torques for Lambda probe; refer to Lambda probes - overview ⇒ page 38**

Protected by copyright. Copying for private or commercial purposes, in part or in whole, is not permitted. Published by Audi AG, Audi AG does not guarantee or accept any liability for the correctness of information in this document. Copyright by AUDI AG.



3 Engine control unit

3.1 Wiring and component check with test box -V.A.G 1598/42-

Special tools and workshop equipment required

- ◆ -V.A.G 1598/39-1-
- ◆ -V.A.G 1598/39-2-
- ◆ Test box -V.A.G 1598/42-

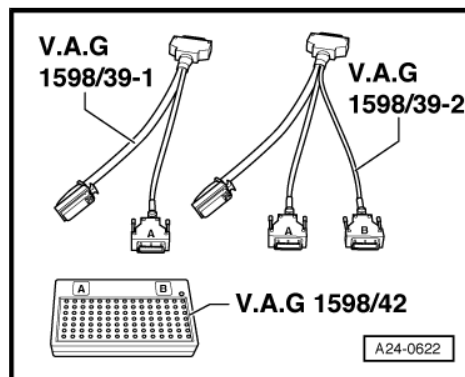

- ◆ Vehicle diagnostic tester



Protected by copyright. Copying for private or commercial purposes, in part or in whole, is not permitted unless authorised by AUDI AG. AUDI AG does not guarantee or accept any liability with respect to the correctness of information in this document. Copyright by AUDI AG.



Note

- ◆ The test box -V.A.G 1598/42- has 105 sockets. It can be connected to the engine control unit via 2 different adapter cables.
- ◆ The engine control unit is connected to the vehicle's wiring harness via two connectors, one of which has 60 pins, the other has 94 pins.
- ◆ To carry out tests on the 60-pin wiring harness connector, the adapter cable -V.A.G 1598/39-1- is connected to connector -A- on the test box. For components connected to 60-pin wiring harness connector → Current flow diagrams, Electrical fault finding and Fitting locations.
- ◆ To carry out tests on the 94-pin wiring harness connector, the adapter cable -V.A.G 1598/39-2- must be connected to connectors -A- and -B- on the test box. For components connected to 94-pin wiring harness connector → Current flow diagrams, Electrical fault finding and Fitting locations.
- ◆ The test box -V.A.G 1598/42- is designed so it can be connected both to the wiring harness for the engine control unit and to the engine control unit itself at the same time. The advantage of this is that the electronic engine control system remains fully functional when the test box is connected (for example, for measuring signals when the engine is running).
- ◆ Always use auxiliary measuring set -V.A.G 1527B- to connect test equipment (e.g. voltage tester -V.A.G 1526E- , hand-held multimeter -V.A.G 1594C- etc.).

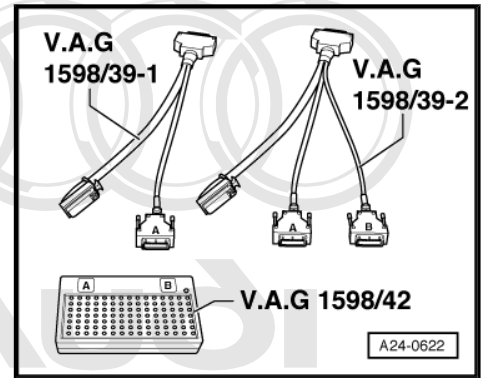

Protected by copyright. Copying for private or commercial purposes, in part or in whole, is not permitted without the prior written authorisation of AUDI AG. AUDI AG does not guarantee or accept any liability for the correctness of information in this document. Copyright by AUDI AG.

The engine control unit has to be removed before connectors can be unplugged from engine control unit ⇒ [page 50](#) .



Caution

To prevent damage to electronic components, select appropriate measuring range before connecting measuring leads and observe test requirements.

- Connect test box -V.A.G 1598/42- to wiring harness connector. The earth clip on the test box must be connected to the negative battery terminal. The instructions for performing the individual tests indicate whether or not the engine control unit itself also needs to be connected to the test box.
- Carry out test as described in appropriate repair procedures.

Installing engine control unit

Installation is performed in the reverse sequence.

- Make sure you fit protective housing (if fitted) back on engine control unit.
- To do so, clean threaded holes for shear bolts to remove remaining locking fluid. This can be done using a thread tap.
- Always use new shear bolts.



The procedure required after connecting the new engine control unit is described in the Guided Fault Finding or Guided Functions.



Note

After completion of the Guided Fault Finding routine, the tester will attempt to erase the event memories of all control units. If this is not successful, the remaining faults registered in the memories must be rectified before all fault entries can be erased.

3.2 Removing and installing engine control unit

Special tools and workshop equipment required

- ◆ Hot air blower -VAS 1978/14A- -item 1- with nozzle attachment -2- from wiring harness repair set -VAS 1978 B-
- ◆ Small, commercially available mole grips -3-

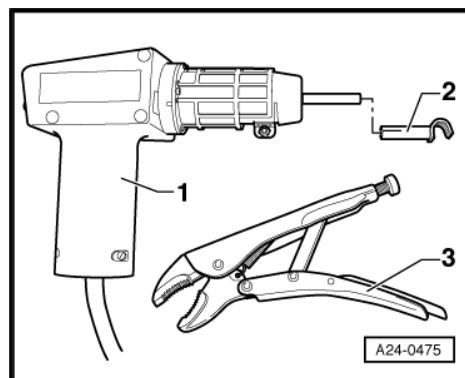

Removing



Note

- ◆ Not every engine control unit is bolted to a protective housing. Whether a protective housing is fitted depends on the engine/gearbox combination.
- ◆ The engine control unit -1- is bolted to the protective housing -4-. To make it more difficult to unscrew the shear bolts -3- for locking plate -2-, their threads have been coated with locking fluid.
- ◆ The protective housing has to be removed before the connectors can be unplugged from the engine control unit (e.g. to connect the test box or renew the engine control unit).

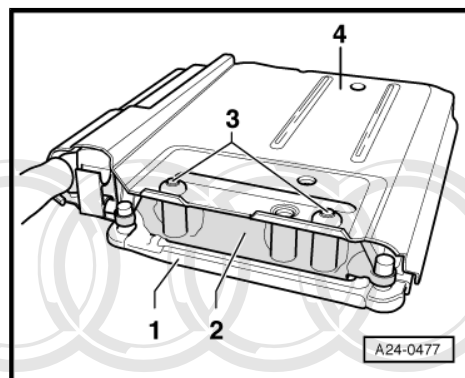

- When renewing engine control unit, select diagnosis object „Replace engine control unit“ in „Guided Functions“. Use vehicle diagnostic tester to do so.
- Switch off ignition and remove ignition key.

Protected by copyright. Copying for private or commercial purposes, in part or in whole, is not permitted unless authorised by AUDI AG. AUDI AG does not guarantee or accept any liability with respect to the correctness of information in this document. Copyright by AUDI AG.

- Remove seal -1- for plenum chamber covers.
- Pull off plenum chamber cover -2- (right-side)

 **Note**

Disregard -item 3-.

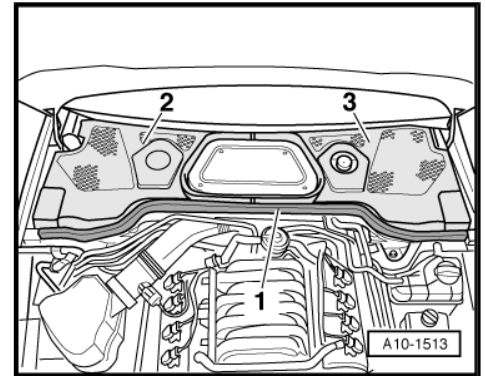

- Unclip cover for engine control unit.
- Remove bolts -arrows-.
- Detach both retainers and engine control unit from electronics box (plenum chamber).

Perform the following work steps only if a protective housing is fitted:

- Lay aside engine control unit with electrical connectors attached.
- Disconnect 81-pin connector at engine control unit.

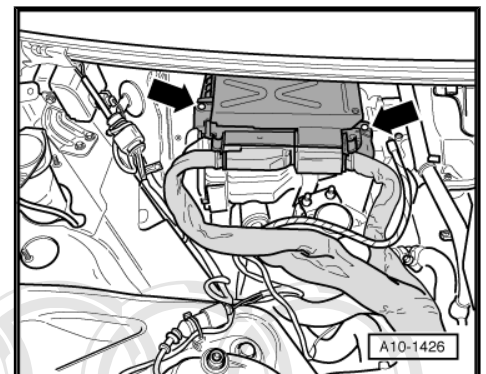

 **Note**

- ◆ *The 60-pin connector is secured with the protective housing and remains attached when removing the engine control unit.*
- ◆ *When the multi-pin connectors are unplugged from the engine control unit, the learnt values are erased, but the contents of the event memory remain intact.*

 **Caution**

Wiring, connectors, insulation and control units can be burnt and damaged.

- ◆ **Keep exactly to the following procedure. Observe the instructions for operating the hot air blower.**

Protected by copyright. Copying for private or commercial purposes, in part or in whole, is not permitted unless authorised by AUDI AG. AUDI AG does not guarantee or accept any liability with respect to the correctness of information in this document. Copyright by AUDI AG.

- Select settings on hot air blower as shown in illustration, i.e. set temperature potentiometer -2- to max. heat output and two-stage air flow switch -3- to position „3“.

 **Note**

Then use hot air blower to heat threaded holes in protective housing into which shear bolts have been screwed. This reduces the inhibiting action of the locking fluid on the shear bolt threads and makes it easier to unscrew these bolts.

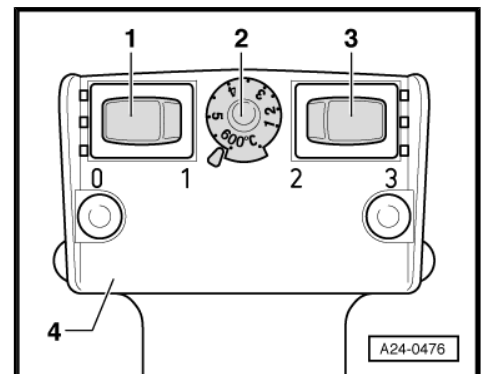



WARNING

Risk of burn injuries.

◆ *Parts of the protective housing will become very hot as a result of heating the shear bolts. Try to ensure that only the shear bolt is heated and none of the nearby components. These should be covered if necessary.*

- Carry out the following operations on the two shear bolts -4- in turn.
- Direct nozzle -1- of hot air blower at shear bolt -2- of protective housing. You can rest the nozzle on the top section of the protective housing.
- Switch on the hot air blower and heat the bolt for approximately 20 ... 25 seconds.
- Grasp head of bolt -2- with vice-grip pliers -1- and unscrew shear bolt -arrows-.
- Repeat the procedure for the 2nd shear bolt.



Note

Be particularly careful here, as this shear bolt is in the immediate vicinity of control unit connector.

- Release connectors on engine control unit and unplug connectors.
- Take out old engine control unit -J623- and install new engine control unit -J623- .

Installing

Installation is performed in the reverse sequence.

- Make sure you fit protective housing (if fitted) back on engine control unit.
- Clean threaded holes for shear bolts to remove any residue from locking fluid. This can be done using a thread tap.
- Always use new shear bolts.
- Carefully clip cowl panel trim into retainer at windscreen.

The procedure required after connecting the new engine control unit is described in the Guided Fault Finding or Guided Functions.

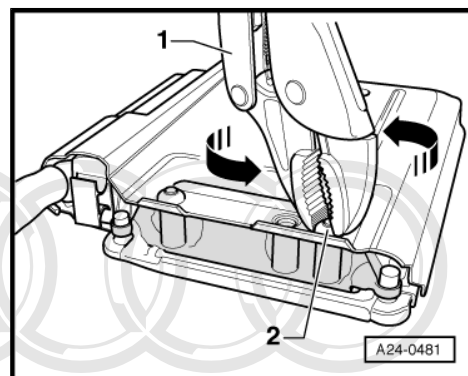
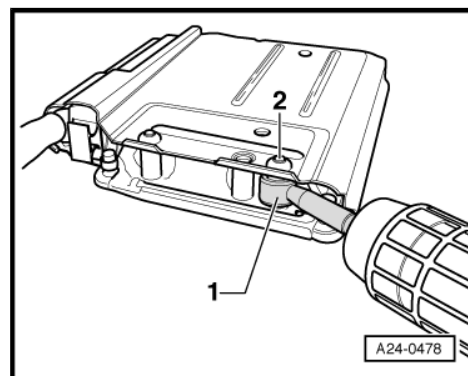
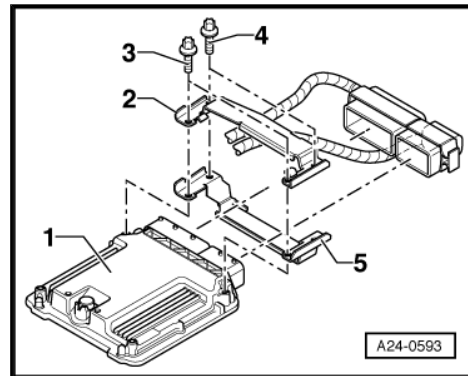

Protected by copyright. Copying for private or commercial purposes, in part or in whole, is not permitted unless authorised by AUDI AG. AUDI AG does not guarantee or accept any liability with respect to the correctness of information in this document. Copyright by AUDI AG.

28 – Ignition system

1 General notes and safety precautions

- ◆ The engine control unit has a self-diagnosis capability.
- ◆ A voltage of at least 11.5 V is required for proper operation of the electrical components.
- ◆ Certain tests may lead to a fault being detected by the control unit and stored. The event memory should therefore be interrogated and (if necessary) erased after completing the tests and any repair work that may be required.
- ◆ If the engine starts, runs for a short period and then cuts out after completing fault finding repairs or component tests, this may be due to the immobiliser disabling the engine control unit. The event memory must then be interrogated and, if necessary, the control unit must be adapted.

1.1 Safety precautions

Note the following if testers and measuring instruments have to be used during a road test:



WARNING

Accidents can be caused if the driver is distracted by test equipment while road-testing, or if test equipment is not properly secured.

Persons sitting in the front passenger's seat could be injured if the airbag is triggered in an accident.

- *The use of test equipment while driving causes distraction.*
- *There is an increased risk of injury if test equipment is not secured.*
- ◆ *Test equipment must always be secured on the rear seat with a strap and operated from the rear seat by a second person.*

To prevent injuries to persons and/or irreparable damage to the fuel injection and ignition system, the following must be noted:

- ◆ Do not touch or disconnect ignition wiring when the engine is running or being turned at starter speed.
- ◆ The ignition must be switched off before disconnecting or connecting ignition system wiring, high-voltage wires and test leads.
- ◆ If you want to crank the engine at starting speed without actually starting it (e.g. compression test), first unplug the connectors from the ignition coils and the injectors. After completing the work, interrogate and erase the event memory.
- ◆ Always switch off the ignition before cleaning the engine.

2 Servicing ignition system

2.1 Test data

Test data		2.8 ltr. / 4V / 154 kW engine
Idling speed (not adjustable)		650 ... 750 rpm ¹⁾
Maximum rpm governed by deactivation of fuel injectors		approx. 6200 rpm
Ignition timing		Not adjustable (determined by control unit)
Ignition system		Multi-coil system with 6 ignition coils (output stages integrated) connected directly to spark plugs
Spark plugs	Designations	⇒ Data sheets for exhaust emissions test
	Tightening torque	⇒ Maintenance ; Booklet 404
Firing order		1-5-3-6-2-4
• ¹⁾ Depending on demands placed on engine control unit.		

2.2 Ignition system - exploded view

1 - Connector for ignition coil

- 4-pin

2 - Bolt

- 10 Nm

3 - 3-pin connector

4 - Hall sender

- Hall sender -G40- (cylinder bank 1)
- Hall sender 3 -G300- (cylinder bank 1)
- Hall sender 2 -G163- (cylinder bank 2)
- Hall sender 4 -G301- (cylinder bank 2)

5 - O-ring

- Renew if damaged
- Lubricate lightly with clean engine oil

6 - Bolt

- 20 Nm
- Tightening torque influences the function of the knock sensor

7 - Knock sensors

- Contact surfaces between knock sensor and cylinder block must be free of corrosion, oil and grease.
- Knock sensor 1 -G61- (cylinder bank 1)

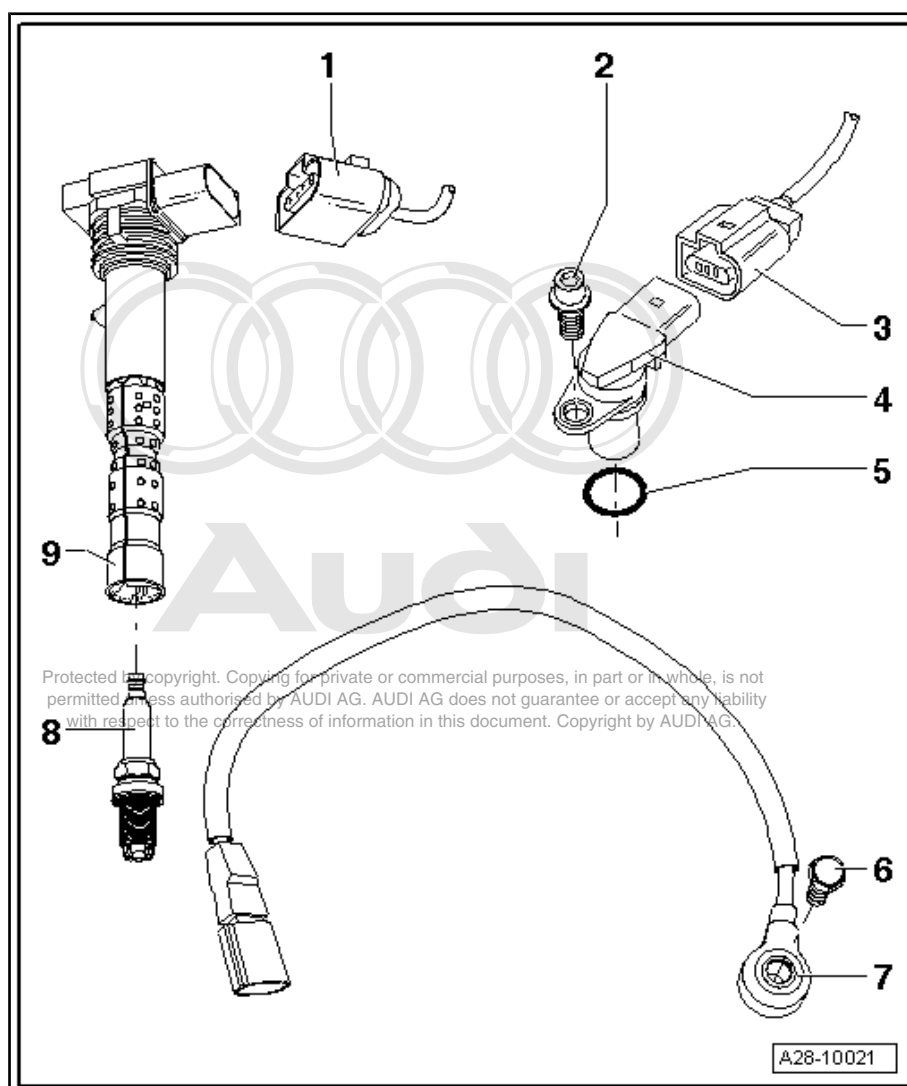

- Knock sensor 2 -G66- (cylinder bank 2)
- Removing and installing => [page 56](#)

8 - Spark plug

- Remove and install with spark plug socket and extension -3122 B- => Maintenance ; Booklet 404
- 30 Nm

9 - Ignition coil

- Ignition coil 1 with output stage -N70-
- Ignition coil 2 with output stage -N127-
- Ignition coil 3 with output stage -N291-
- Ignition coil 4 with output stage -N292-
- Ignition coil 5 with output stage -N323-
- Ignition coil 6 with output stage -N324-
- Removing and installing => [page 55](#)
- Use puller -T40039- for removal

2.3 Removing and installing ignition coils

Special tools and workshop equipment required

- ◆ Puller -T40039-

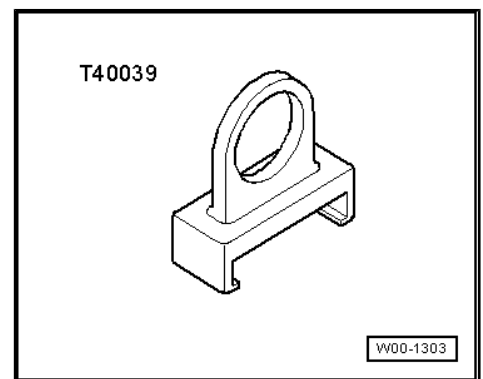

Removing

- Pull off engine cover panels -arrows-.



Note

Fit all cable ties in the original positions when installing.

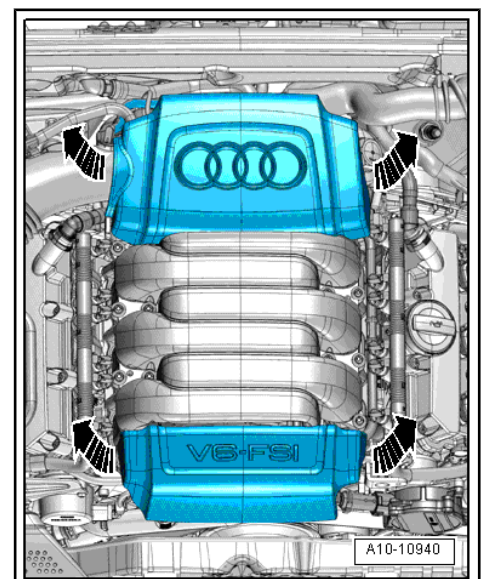

Protected by copyright. Copying for private or commercial purposes, in part or in whole, is not permitted unless authorised by AUDI AG. AUDI AG does not guarantee or accept any liability with respect to the correctness of information in this document. Copyright by AUDI AG.

**Cylinder bank 1 (right-side)**

- Loosen hose clip -2- and remove air hose.
- Detach vacuum hose -3-.
- Unscrew bolts -arrows- and remove air cleaner housing.

**Note**

Disregard -item 1-.

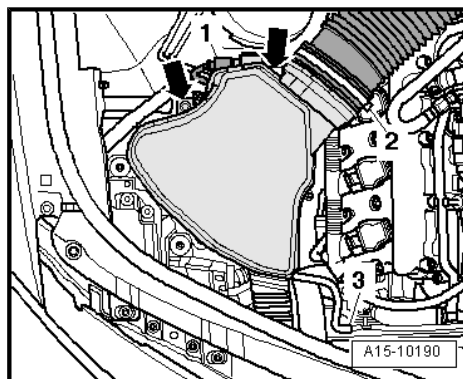
**Continuation for both sides**

- Remove bolts -arrows-.
- Unplug electrical connectors from ignition coils and move wiring harness to one side.

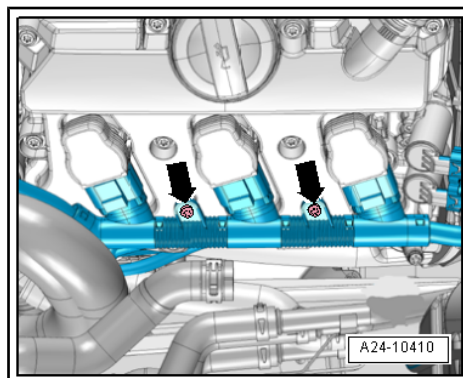

- Slide puller -T40039- onto ignition coil with output stage, and pull off ignition coil in direction of -arrow-.

Installing

- Fit all ignition coils loosely into spark plug holes.
- Align the ignition coils with the connectors and attach all connectors onto ignition coils simultaneously.
- Press ignition coils onto spark plugs by hand evenly (do NOT use tool).

The remaining installation steps are carried out in the reverse sequence.

- Tightening torque for wiring guide for ignition coils to cylinder head cover: 5 Nm

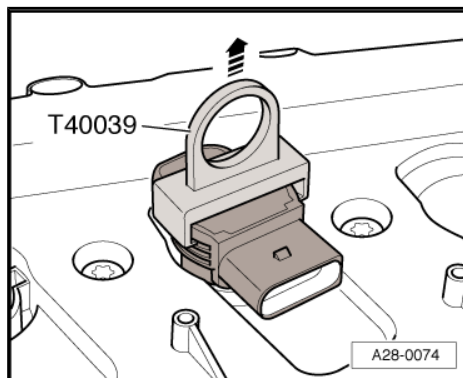
**2.4 Removing and installing knock sensors****WARNING**

- ◆ **The fuel system operates under high pressure. The pressure in the high-pressure part of the injection system must be reduced to a residual pressure prior to opening the system => page 2.**
- ◆ **A clean cloth must then be wrapped around the connection and the residual pressure dissipated by carefully loosening the connection.**

Protected by copyright. Copying for private or commercial purposes, in part or in whole, is not permitted unless authorized by AUDI AG. AUDI AG does not guarantee or accept any liability with respect to the correctness of information in this document. Copyright by AUDI AG.

Removing

- Remove intake manifold ⇒ [page 19](#) .

Electrical connectors for knock sensors at rear left of engine

- 1 - To knock sensor 1 -G61-
- 2 - To knock sensor 2 -G66-
- To injectors on cylinder bank 2 and to fuel pressure sender - G247-

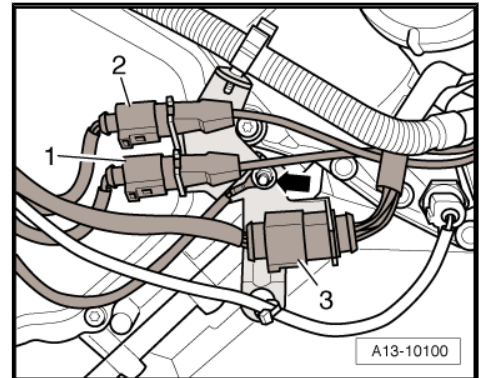

- Remove knock sensor 1 -G61- -4-.

i Note

Fitting locations below intake manifold on cylinder bank 1 (right-side)

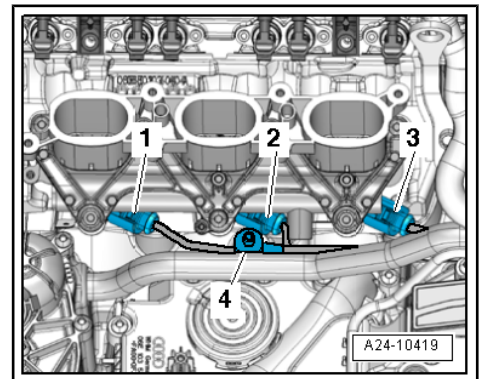

- Remove knock sensor 2 -G66- -5-.

i Note

Fitting locations below intake manifold on cylinder bank 2 (left-side)

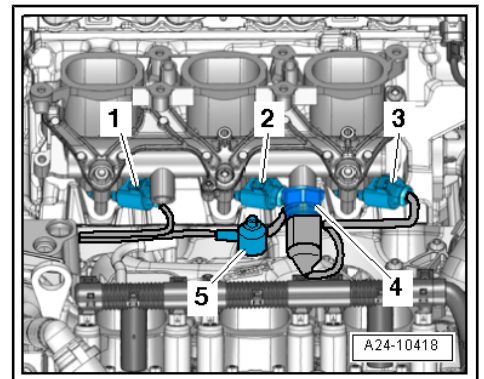

Installing

- Secure relevant knock sensor (removed before) at fitting location.

i Note

Tightening torque influences the function of the knock sensors.

- Tightening torque: refer to exploded view of ignition system ⇒ [page 54](#) .
- Install intake manifold ⇒ [page 19](#) .

Audi

Protected by copyright. Copying for private or commercial purposes, in part or in whole, is not permitted unless authorised by AUDI AG. AUDI AG does not guarantee or accept any liability with respect to the correctness of information in this document. Copyright by AUDI AG.